



Standard Inventory Item

7x57 Mauser

2EA938

Manson Reamers

Contact us at:
support@mansonreamers.com
(810) 953-0732

8200 Embury Rd
Suite 1
Grand Blanc, MI 48439

7x57 Mauser

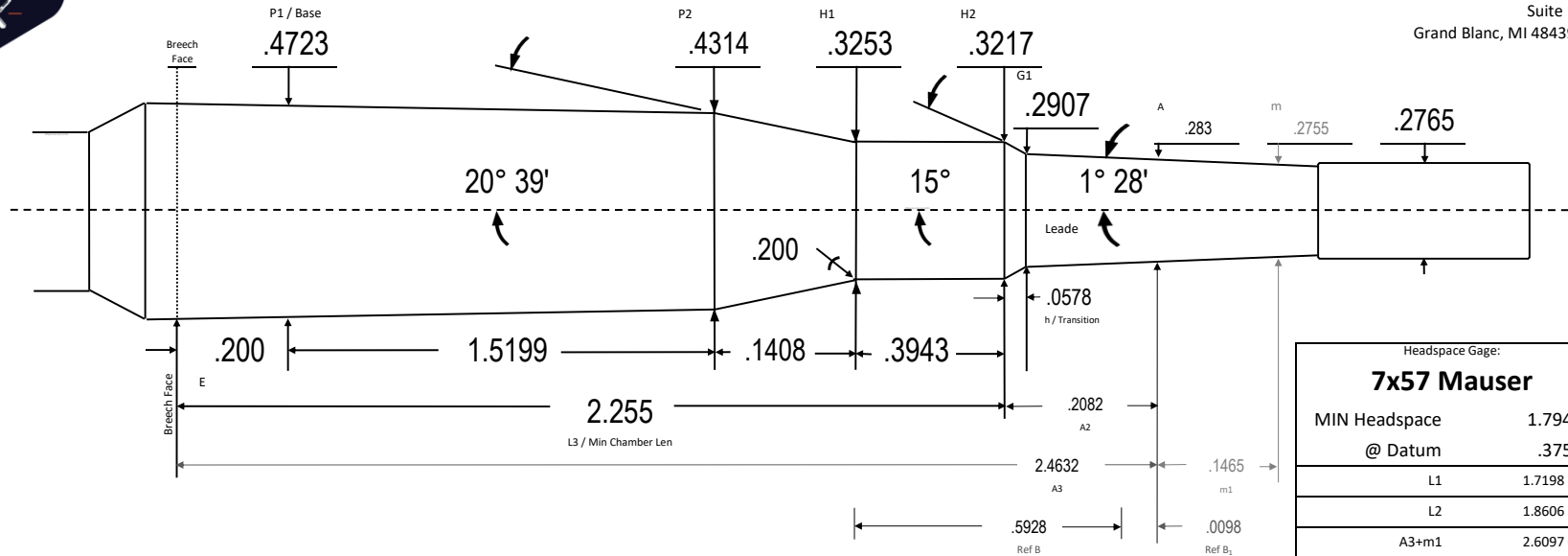

vrfd SAAMi 9/12/22, 12/15/22, 24.02.23 rg ex bore & groove standard .277x.284

Reamers made prior to 03/24 will have .470 dia @ .200 line

Headspace Gage:	
7x57 Mauser	
MIN Headspace	1.7947
@ Datum	.3750
L1	1.7198 73
L2	1.8606 38
A3+m1	2.6097 00
Body TPI	.0269 10
Breech Face Dia	.4776 82
~Chamber Vol in ³	.2952 57
Drawn:	Ray Gross
SD	2024.02.23
Template TT	V10.2 24.01.10
Dia Tolerance	+ .001 / - .000
Length Tolerance	+ .005 / - .000
Angle Tolerance	+ / - 15'
Use Reamer Blank	7x57
Print is not to scale	



7x57 Mauser

7x57 Mauser