



Inventory Item
7.62x25 Tokarev CIP

1507DD

Standard

Manson Reamers

Contact us at:
 support@mansonreamers.com
 (810) 953-0732

8200 Embury Rd
 Suite 1
 Grand Blanc, MI 48439

7.62x25 Tokarev CIP

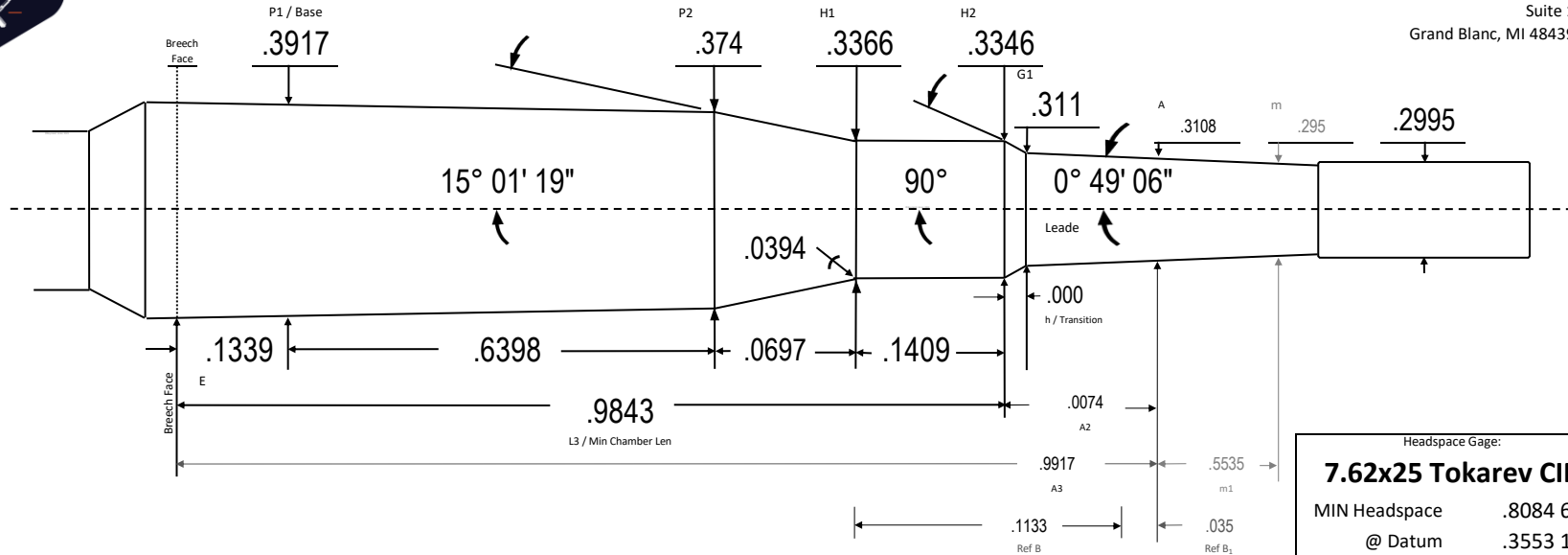

**** Note 90° Transition ****

It is not clear if this cartridge was meant to headspace on the case mouth or the shoulder. L3 for both cartridge and chamber is the same. Manson headspace gages are made to set shoulder position.

[v26.1 2024.01.04] Direct translation of CIP specification (ex. bore diameters are std US dimension). [TD:2024/01/04]

cip issue 1990-04-04, revised 2006-09-19

Headspace Gage:	
7.62x25 Tokarev CIP	
MIN Headspace	.8084 65
@ Datum	.3553 15
L1	.7736 22
L2	.8433 22
A3+m1	1.5452 00
Body TPI	.0276 92
.200 line Base Dia	.3899 01
~Chamber Vol in ³	.0968 75
Drawn:	Ray Gross
Print Hash	1507DD
Use Reamer Blank	0
Template TT	V10 2023.12.28
Dia Tolerance	+0.01/-0.00
Length Tolerance	+0.005/-0.000
Angle Tolerance	+/- 15'
Print is not to scale	

7.62x25 Tokarev CIP

7.62x25 Tokarev CIP