



Standard Inventory Item
6.8 Western

E31DEA

9/23/2020

11/17/2021

Revision

Manson Reamers

Contact us at:
support@mansonreamers.com
(810) 953-0732

8200 Embury Rd
Suite 1
Grand Blanc, MI 48439

6.8 Western

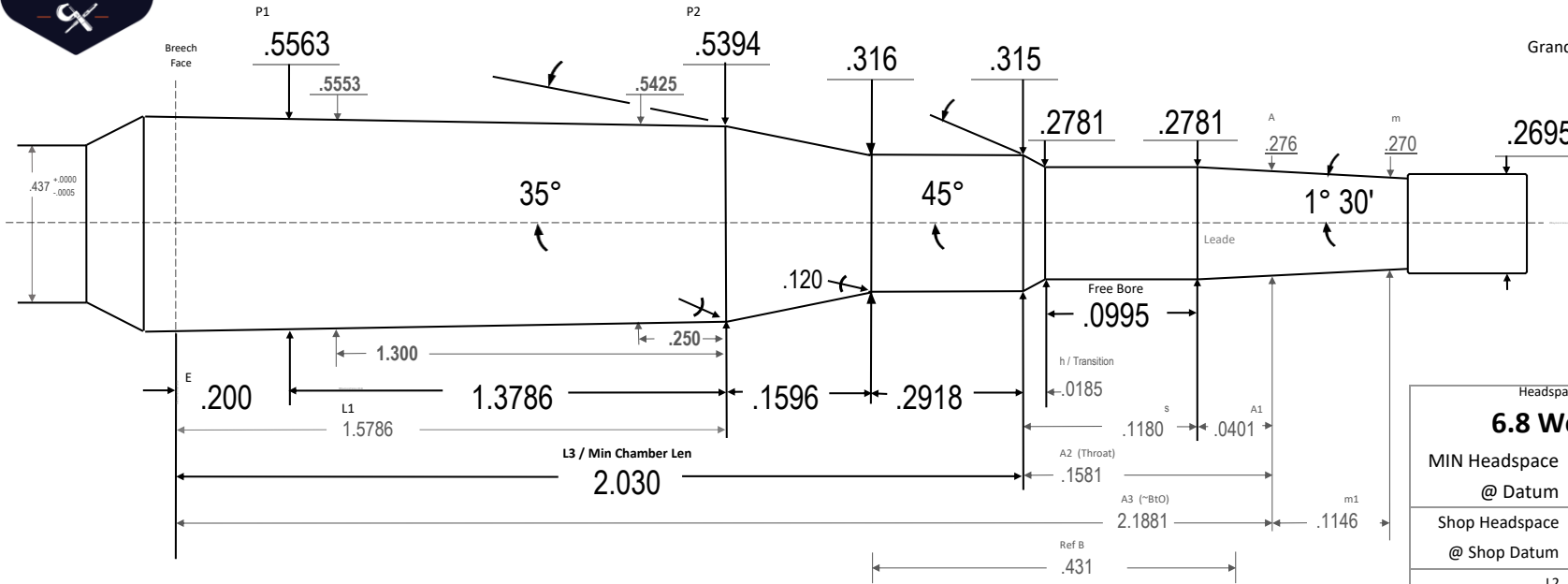

Verified SAAMI 2024 24.04.16rg

Headspace Gage:	
6.8 Western	
MIN Headspace	1.6460
@ Datum	.4450
Shop Headspace	1.6514
@ Shop Datum	.4375
L2	1.7381 16
A3+m1	2.3026 65
Body TPI	.0122 31
Breech Face Dia	.5587 46
~Chamber Vol in ³	.3972 95
Drawn:	Ray Gross
SD	2024.06.27
Template PTL	V10.4 24.06.08
Dia Tolerance	+.001/- .000
Length Tolerance	+.005/- .000
Angle Tolerance	+/- 15'
Use Reamer Blank	270/7 WSM
Print is not to scale	



6.8 Western

6.8 Western