



Standard Inventory Item
6.5-06 A-Square

06D84C

01/29/1997

Manson Reamers

Contact us at:
support@mansonreamers.com
(810) 953-0732

8200 Embury Rd
Suite 1
Grand Blanc, MI 48439

6.5-06 A-Square

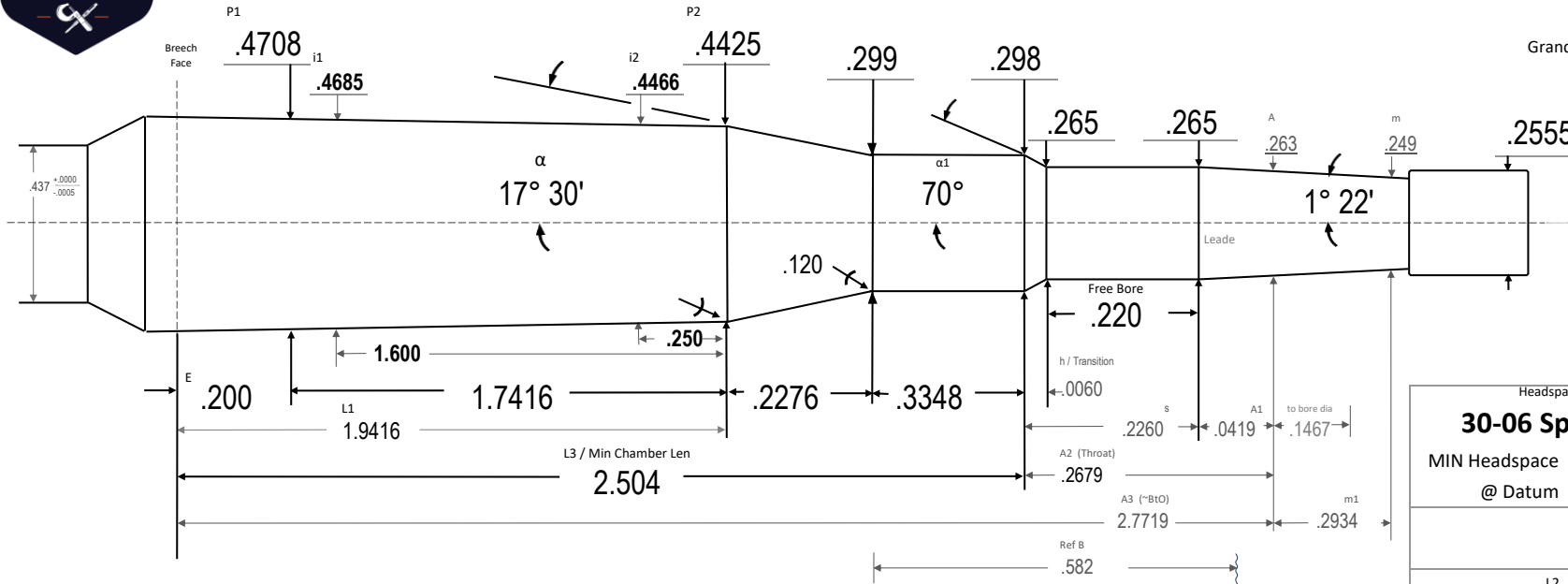

Per delisted SAAMI print dated 1/29/97, re-pub 12/7/1999 - Translated 2024.08.06

Notes:

The A-Square has a very long throat resulting in most bullets jumping a significant amount.

30-06 Headspace gages are commonly used to headspace the 6.5-06 A-Square despite the minor difference in shoulder angle.

Headspace Gage:	
30-06 Springfield	
MIN Headspace	2.0487
@ Datum	.3750
L2	2.1692 21
Len- Breech to Bore dia	2.9186 21
Body TPI	.0162 42
Breech Face Dia	.4740 48
~Chamber Vol in ³	.3452 78
Drawn:	Ray Gross
SD	2024.08.06
Template PTL	V10.6 24.08.01
Dia Tolerance	+.001/- .000
Length Tolerance	+.005/- .000
Angle Tolerance	+/- 15'
Use Reamer Blank	0
Print is not to scale	



6.5-06 A-Square

6.5-06 A-Square