



Manson Precision Reamers

8200 Embury Rd, Grand Blanc, MI 48439

(810) 953-0732

support@mansonreamers.com

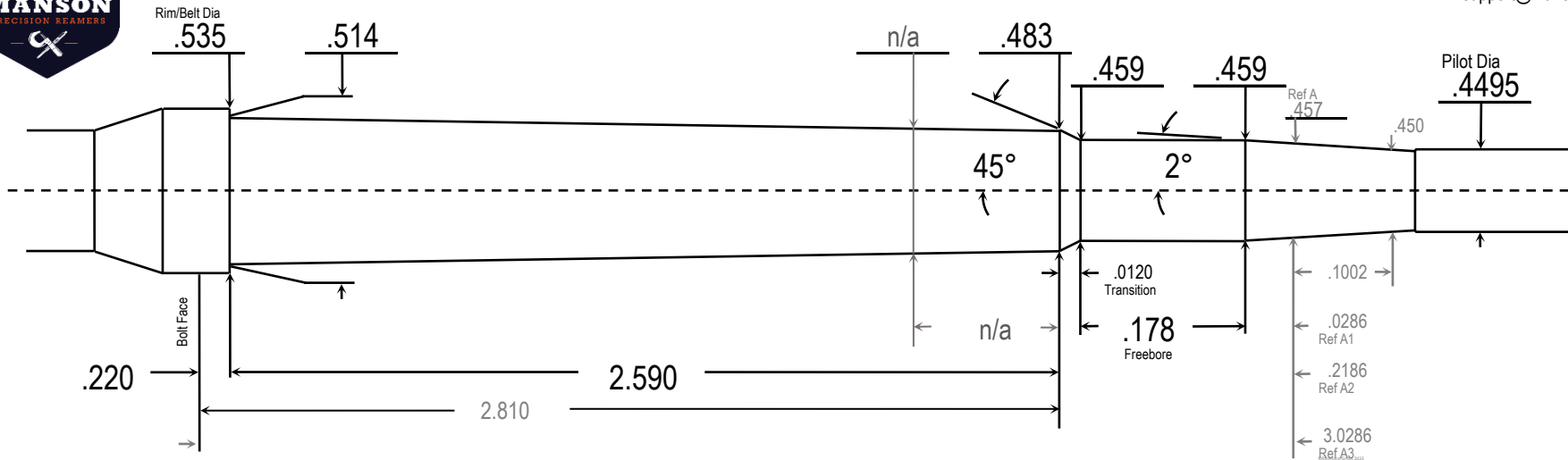

458 Lott

Standard

0

Design Date

Revision

SAAMI 2015 vrfd 10/27/22rg

Adopted as Manson Standard Nov 2023. Reamers dated prior used a close variation designed by Dave Manson

458 Lott

Headspace Gage:	
Std Belted Mag	
MIN Headspace	.220
Gage Rim/Belt Dia	.530
Dia Tolerance	+.001/-.000
Length Tolerance	+.005/-.000
Angle Tolerance	+/- 10'
Body TPI	.011969
Drawn:	R Gross
Template	DDBR SWPT
SD	2023.11.21
Print not to scale	
