



Standard Inventory Item
35 Whelen SAAMI

E94F03

1/8/1988

7/28/2022

Revision

Manson Reamers

Contact us at:
 support@mansonreamers.com
 (810) 953-0732

8200 Embury Rd
 Suite 1
 Grand Blanc, MI 48439

35 Whelen SAAMI

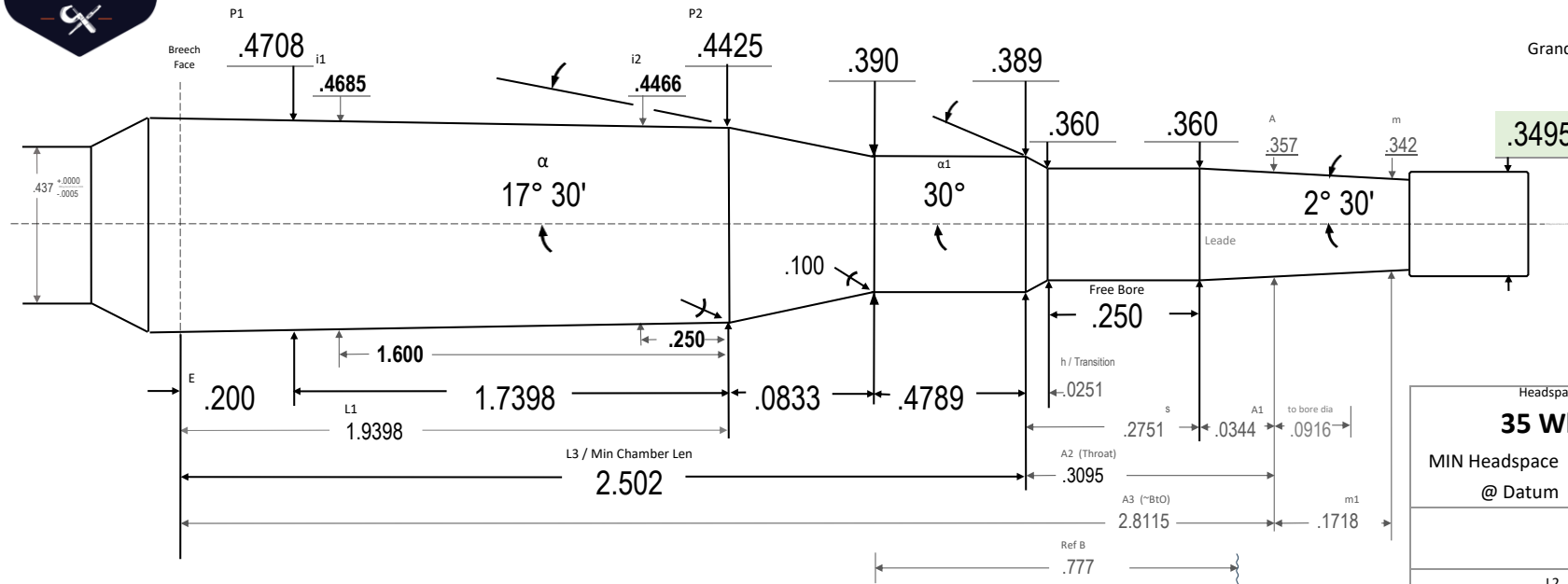

| Headspace Gage: | |
|------------------------------|----------------|
| 35 Whelen | |
| MIN Headspace | 1.9835 |
| @ Datum | .4150 |
| L2 | 2.0231 45 |
| Len- Breech to Bore dia | 2.9030 71 |
| Body TPI | .0162 42 |
| Breech Face Dia | .4740 48 |
| ~Chamber Vol in ³ | .3314 72 |
| Drawn: | Ray Gross |
| SD | 2024.08.04 |
| Template PTL | V10.6 24.08.01 |
| Dia Tolerance | +.001/- .000 |
| Length Tolerance | +.005/- .000 |
| Angle Tolerance | +/- 15' |
| Use Reamer Blank | 35 Whel |
| Print is not to scale | |

30-06 headspace gauges can be -and- generally are used to headspace the Whelen. Technically, SAAMI headspace for the Whelen is .0015 shorter than the 30-06 at the .375 datum. SAAMI spec 35 Whelen gages are available as a custom item. In practice, any differences are immaterial.

SAAMI 2024 verified 24.04.22rg

35 Whelen SAAMI

35 Whelen SAAMI

