



Standard Inventory Item

# 35 Whelen Ackley Imp

204230

5/30/1999

**Manson Reamers**

Contact us at:  
support@mansonreamers.com  
(810) 953-0732

8200 Embury Rd  
Suite 1  
Grand Blanc, MI 48439

35 Whelen Ackley Imp

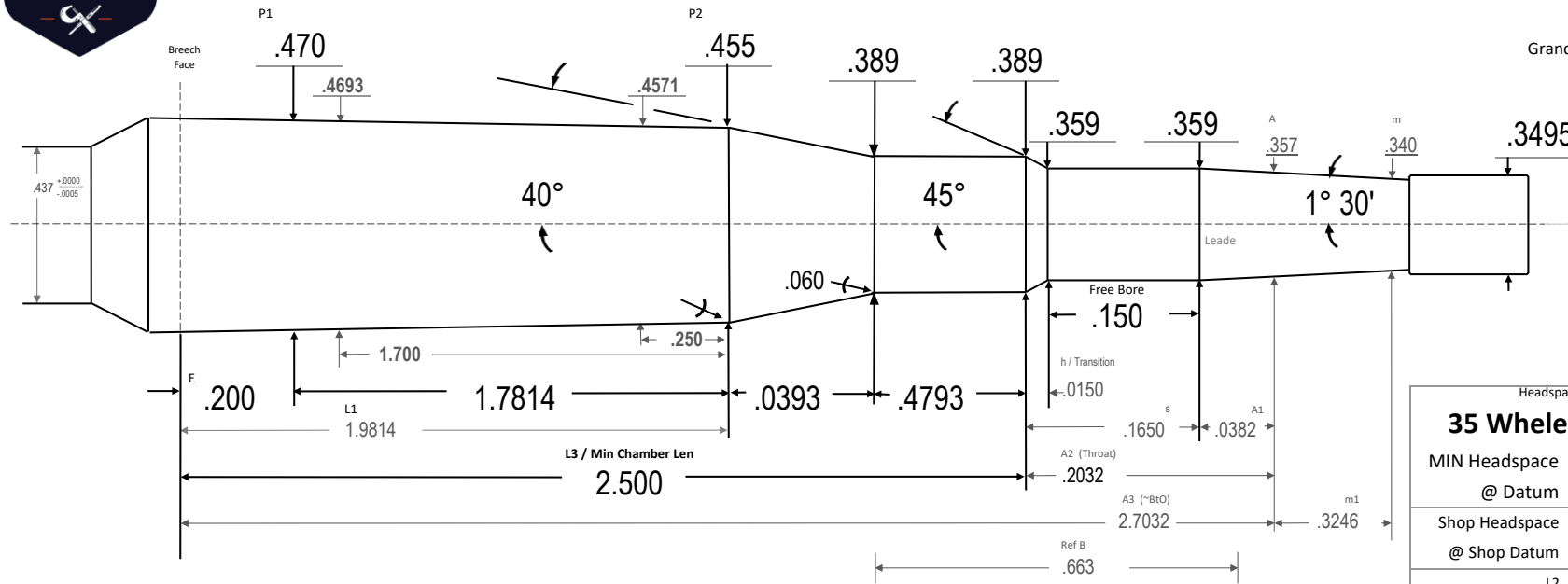

Standard Ackley conversion by D Manson

Standard and Ackley 30-06 gages are typically used to headspace the Whelen. (Technically the Whelen headspace is .0015 shorter than the 30-06, but immaterial in practice).

Headspace Gage:	
<b>35 Whelen ACK GO</b>	
MIN Headspace	2.0207
@ Datum	.3890
Shop Headspace	
@ Shop Datum	
L2	2.0207 31
Len- Breech to Bore dia	2.8368 48
Body TPI	.0084 2
Breech Face Dia	.4716 84
~Chamber Vol in <sup>3</sup>	.3396 36
Drawn:	Ray Gross
SD	2024.07.21
Template PTL	V10.5 24.07.11
Dia Tolerance	+.001/- .000
Length Tolerance	+.005/- .000
Angle Tolerance	+/- 15'
Use Reamer Blank	35 Whel
Print is not to scale	



35 Whelen Ackley Imp

35 Whelen Ackley Imp