



# 338 Lapua Mag CIP

6235E9

1989-09-09

2016-10-18

Revision

## Manson Reamers

Contact us at:  
support@mansonreamers.com  
(810) 953-0732

8200 Embury Rd  
Suite 1  
Grand Blanc, MI 48439

338 Lapua Mag CIP

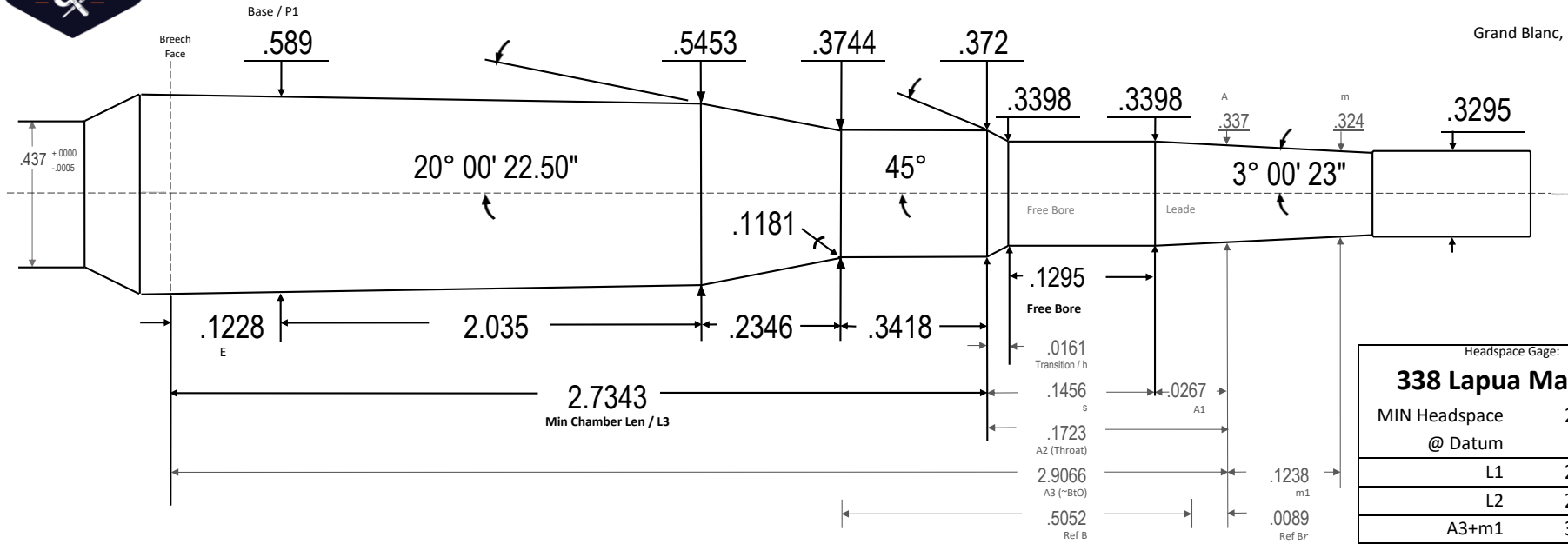

[v26.2023.04.25] Direct translation of CIP specification (ex. bore diameters are std US dimension). [TD:2023/06/08]

Interchangeable with SAAMI

Headspace Gage:	
<b>338 Lapua Mag CIP</b>	
MIN Headspace	2.3059
@ Datum	.4375
L1	2.1579
L2	2.3925
A3+m1	3.0304
Body TPI	.0214742
.200 line Base Dia	.5873
~Chamber Vol in <sup>3</sup>	.5873
Drawn:	Ray Gross
(v23.3) Print Hash	6235E9
Template PTL	V8.5 2023.06.07
Dia Tolerance	+.001/- .000
Length Tolerance	+.005/- .000
Angle Tolerance	+/- 15'
Use Reamer Blank	0
Print is not to scale	



338 Lapua Mag CIP

338 Lapua Mag CIP