



Standard Inventory Item

# 338 Federal

2E0077

06/28/2006

02/08/2022

Revision

Manson Reamers

Contact us at:  
support@mansonreamers.com  
(810) 953-0732

8200 Embury Rd  
Suite 1  
Grand Blanc, MI 48439

338 Federal

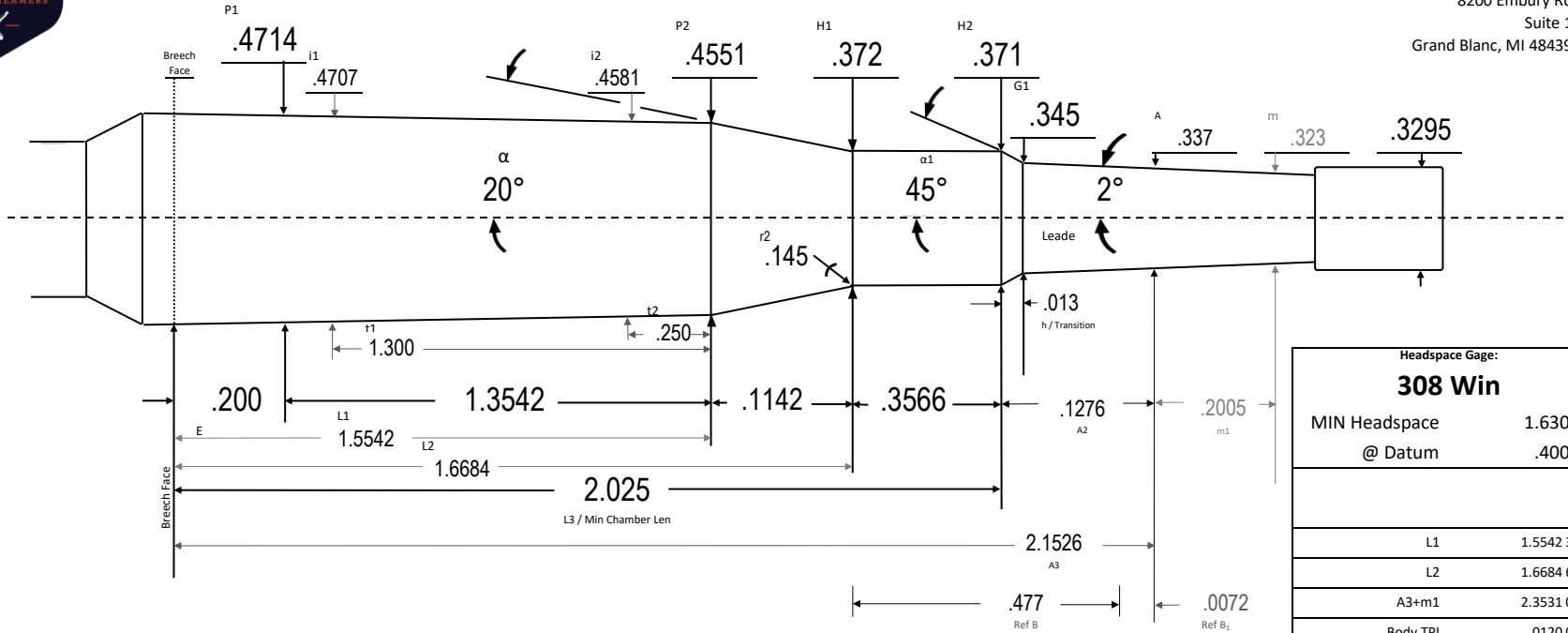

SAAMI 2024 - Translated 2024.08.04

Note that SAAMI lists headspace as 1.6025 to the .420 datum, which is simply .308 Win headspace recalculated to a different datum dia. 308 Win headspace gages are the correct gages to use.

Headspace Gage:	
<b>308 Win</b>	
MIN Headspace	1.6300
@ Datum	.4000
L1	1.5542 39
L2	1.6684 65
A3+m1	2.3531 00
Body TPI	.0120 00
Breech Face Dia	.4738 00
~Chamber Vol in <sup>3</sup>	.2787 78
Drawn:	Ray Gross
SD	2024.08.05
Template TT	V10.6 24.08.01
Dia Tolerance	+ .001 / - .000
Length Tolerance	+ .005 / - .000
Angle Tolerance	+ / - 15'
Use Reamer Blank	0
Print is not to scale	



338 Federal

338 Federal