



Standard Inventory Item
308 Win

F3E255

01/10/2001

08/05/2022

Revision

Manson Reamers

Contact us at:
support@mansonreamers.com
(810) 953-0732

8200 Embury Rd
Suite 1
Grand Blanc, MI 48439

308 Win

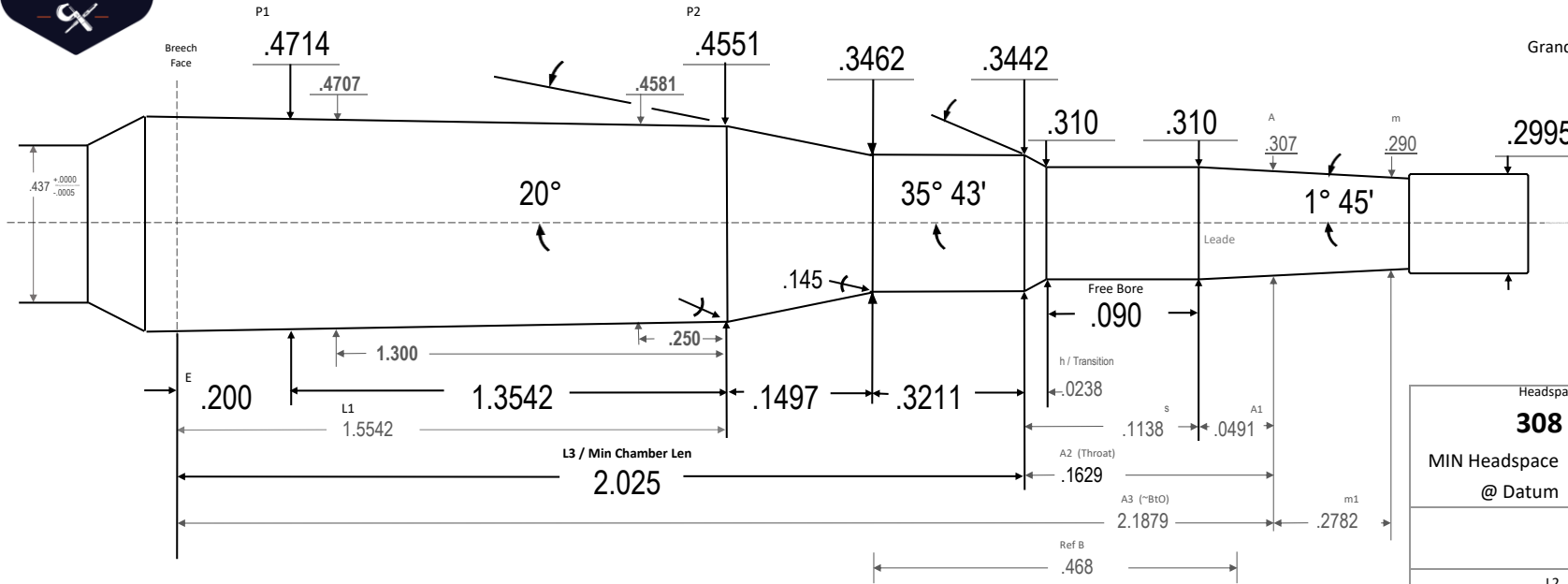

SAAMI 2024 - Translated 2024/05/13 [v1.0 2024.05.13]

Headspace Gage:	
308 Win	
MIN Headspace	1.6300
@ Datum	.4000
L2	1.7039 07
Len- Breech to Bore dia	2.3024 51
Body TPI	.012
Breech Face Dia	.4738
~Chamber Vol in ³	.2823 76
Drawn:	Ray Gross
SD	2024.07.21
Template PTL	V10.5 24.07.11
Dia Tolerance	+.001/- .000
Length Tolerance	+.005/- .000
Angle Tolerance	+/- 15'
Use Reamer Blank	0
Print is not to scale	



308 Win

308 Win