



Standard Inventory Item
300 Savage

49C493

05/29/1979

5/27/2022

Revision

Manson Reamers

Contact us at:
support@mansonreamers.com
(810) 953-0732

8200 Embury Rd
Suite 1
Grand Blanc, MI 48439

300 Savage

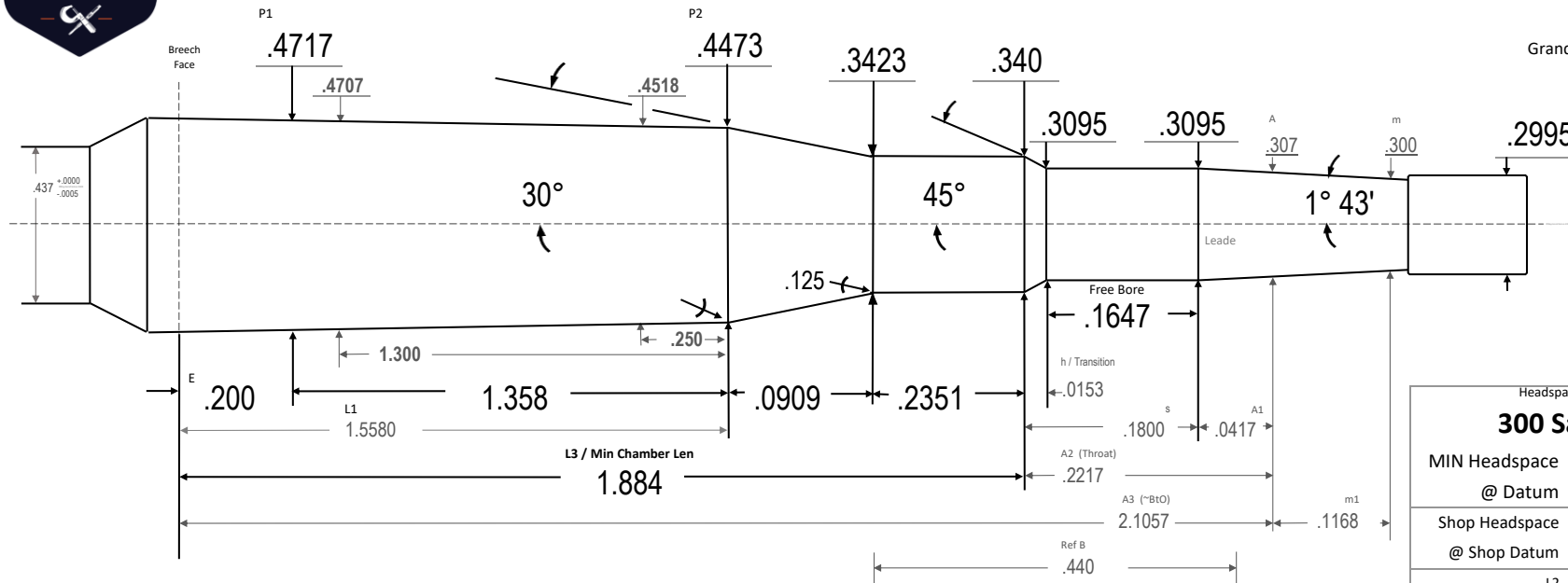

SAAMI 2024 - Translated 2024.05.13

Headspace Gage:	
300 Savage	
MIN Headspace	1.6017
@ Datum	.3968
Shop Headspace	1.6206
@ Shop Datum	.3750
L2	1.6488 98
A3+m1	2.2224 82
Body TPI	.018
Breach Face Dia	.4753
~Chamber Vol in ³	.2716 38
Drawn:	Ray Gross
SD	2024.06.29
Template PTL	V10.4 24.06.08
Dia Tolerance	+.001/- .000
Length Tolerance	+.005/- .000
Angle Tolerance	+/- 15'
Use Reamer Blank	308 Win
Print is not to scale	



300 Savage

300 Savage