



Standard Inventory Item

300 Rem Ultra Mag (300 RUM)

7C08D5

01/07/1999

05/26/2022

Revision

Manson Reamers

Contact us at:
support@mansonreamers.com
(810) 953-0732

8200 Embury Rd
Suite 1
Grand Blanc, MI 48439

300 Rem Ultra Mag (300 RUM)

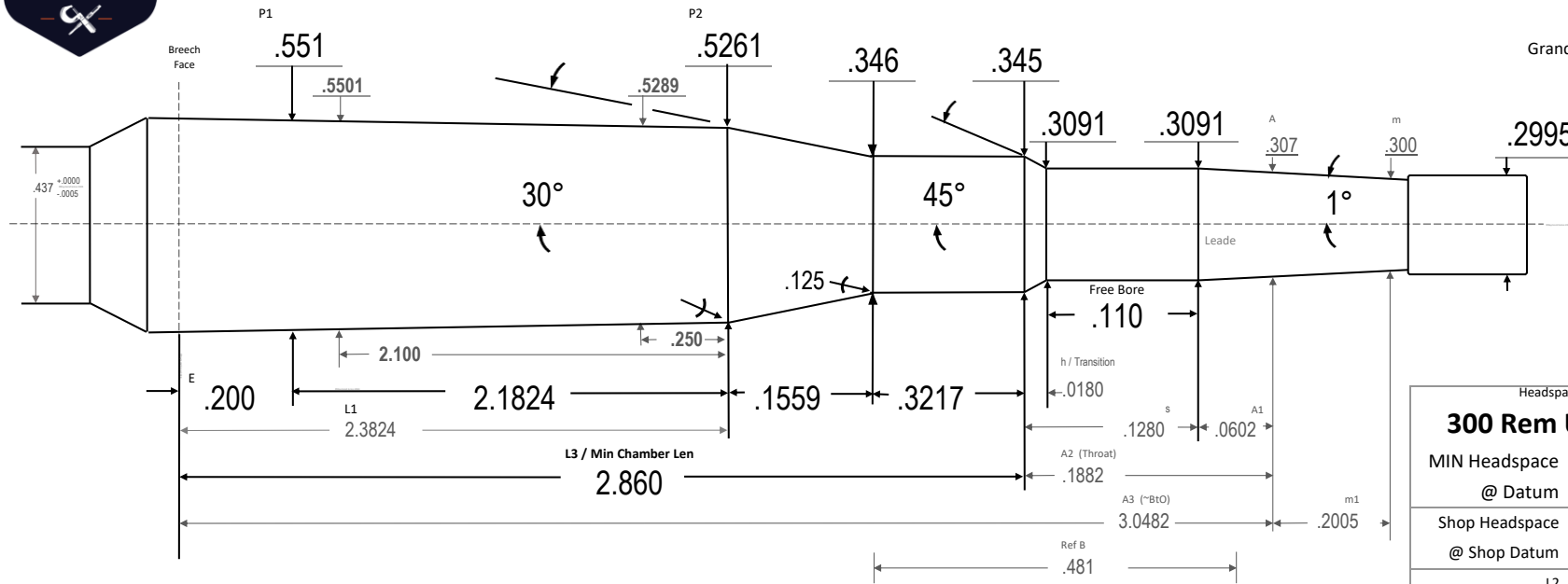

SAAMI 2024 - Translated 2024.06.29

Note that the 7, 300 & 375 use the same gage, the 338 has it's own separate gages/separate hs spec.

Headspace Gage:	
300 Rem Ultra Mag	
MIN Headspace	2.4742
@ Datum	.4200
Shop Headspace	2.4915
@ Shop Datum	.4000
L2	2.5382 86
A3+m1	3.2487 15
Body TPI	.0114 29
Breech Face Dia	.5532 86
~Chamber Vol in ³	.5686 74
Drawn:	Ray Gross
SD	2024.06.29
Template PTL	V10.4 24.06.08
Dia Tolerance	+.001/- .000
Length Tolerance	+.005/- .000
Angle Tolerance	+/- 15'
Use Reamer Blank	0
Print is not to scale	



300 Rem Ultra Mag (300 RUM)

300 Rem Ultra Mag (300 RUM)