



Standard Inventory Item  
**300 Norma Mag CIP**

82E378

2012-05-30

**Manson Reamers**

Contact us at:  
 support@mansonreamers.com  
 (810) 953-0732

8200 Embury Rd  
 Suite 1  
 Grand Blanc, MI 48439

**300 Norma Mag CIP**

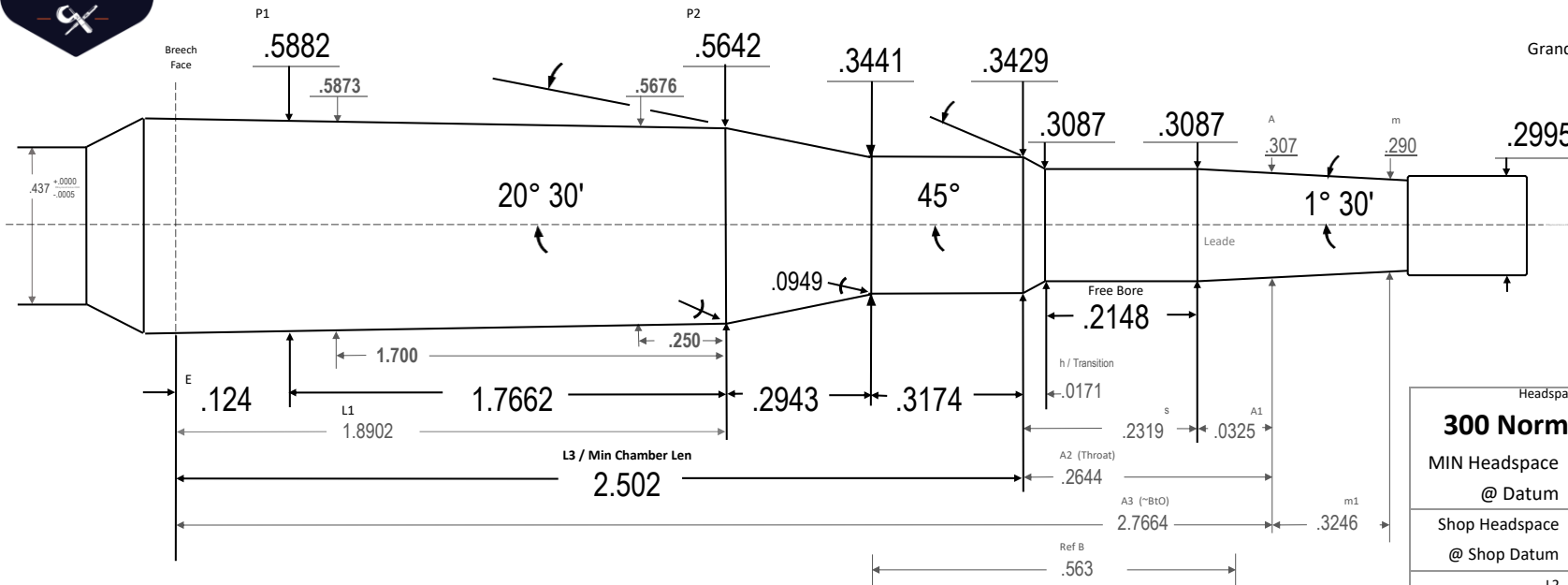

Direct translation of CIP specification 2024/07/09

Headspace Gage:	
<b>300 Norma Mag CIP</b>	
MIN Headspace	2.0374
@ Datum	.4541
Shop Headspace	2.1098
@ Shop Datum	.4000
L2	2.1845 58
Len- Breech to Bore dia	2.8992 41
Body TPI	.0135 97
.200 line Base Dia	.5871 56
~Chamber Vol in <sup>3</sup>	.5429 91
Drawn:	Ray Gross
SD	2024.07.09
Template PTL	V10.4 24.06.08
Dia Tolerance	+ .001/- .000
Length Tolerance	+ .005/- .000
Angle Tolerance	+/- 15'
Use Reamer Blank	0
Print is not to scale	



**300 Norma Mag CIP**

**300 Norma Mag CIP**