



Standard Inventory Item
30 Nosler

B232F3

01/19/2015

05/18/2022

Revision

Manson Reamers

Contact us at:
support@mansonreamers.com
(810) 953-0732

8200 Embury Rd
Suite 1
Grand Blanc, MI 48439

30 Nosler

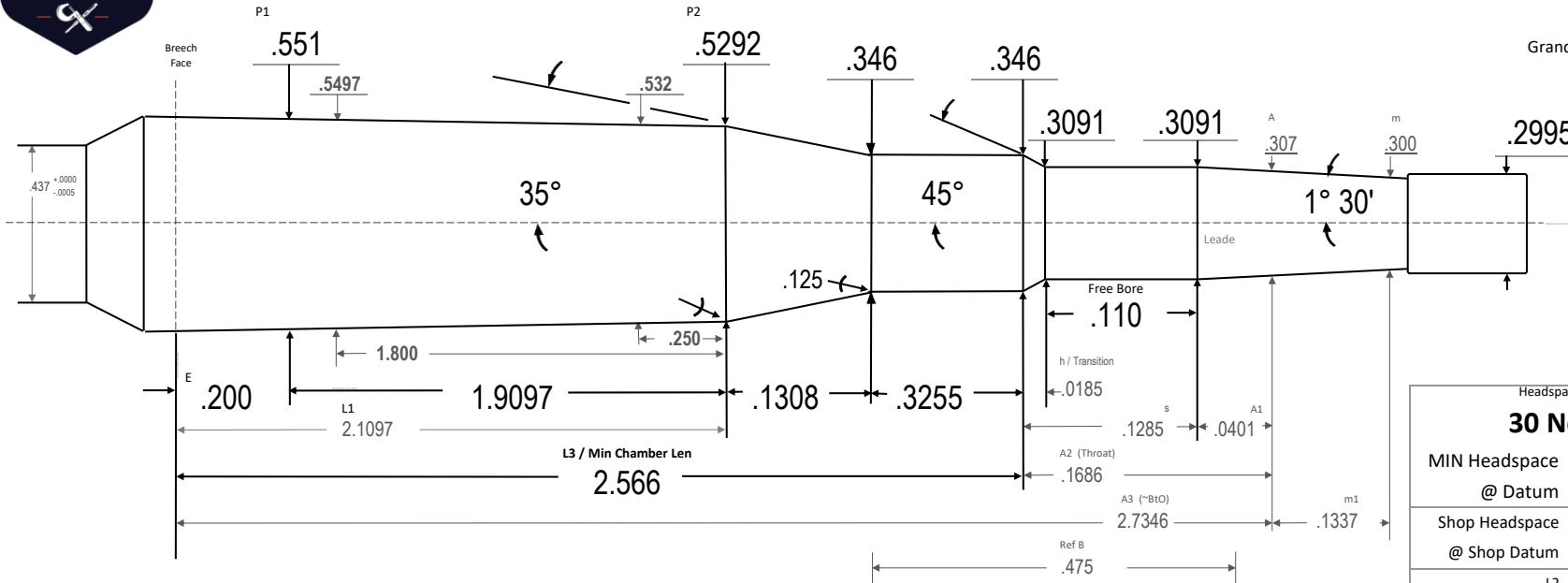

SAAMI 2024 - Translated 2024.06.29

Note that SAAMI 2024 standard made a minor revision to headspace length (2015 standard was 2.188 to .420 datum)

Headspace Gage:	
30 Nosler	
MIN Headspace	2.1877
@ Datum	.4200
Shop Headspace	2.1752
@ Shop Datum	.4375
L2	2.2405 41
A3+m1	2.8682 6
Body TPI	.0114 29
Breech Face Dia	.5532 86
~Chamber Vol in ³	.5054 2
Drawn:	Ray Gross
SD	2024.06.29
Template PTL	V10.4 24.06.08
Dia Tolerance	+.001/- .000
Length Tolerance	+.005/- .000
Angle Tolerance	+/- 15'
Use Reamer Blank	0
Print is not to scale	



30 Nosler

30 Nosler