

Manson Precision Reamers

8200 Embury Rd, Grand Blanc, MI 48439

(810) 953-0732 Fax (810) 953-0735

david@mansonreamers.com

Customer _____

Est/Inv Date _____

Est/Inv Num _____

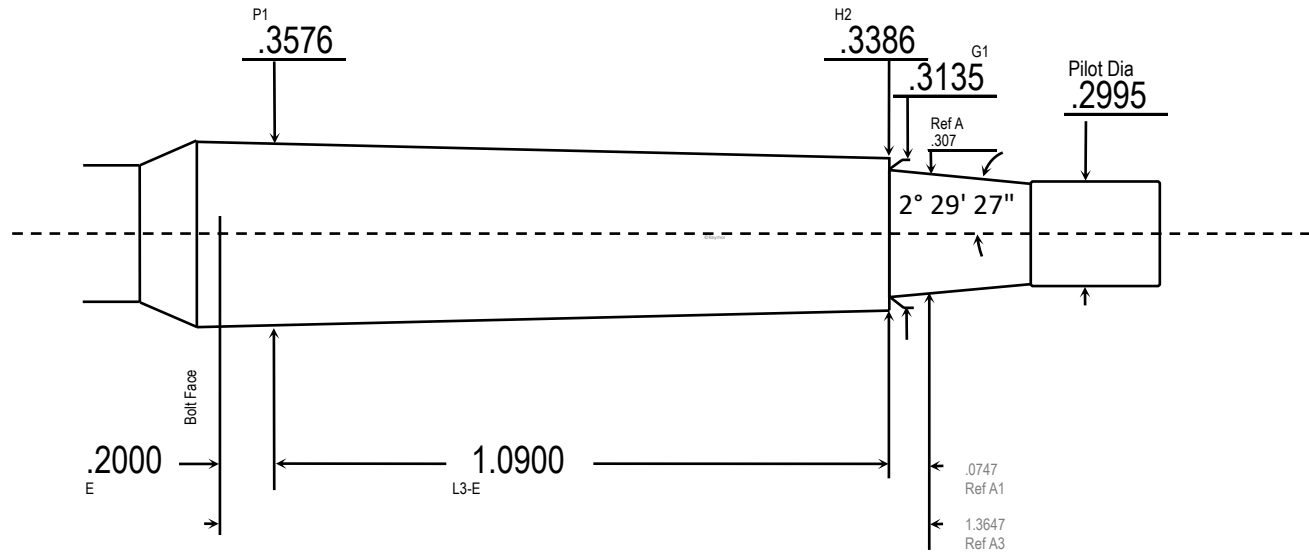

30 Carbine SAAMI

SAAMI 2015

Design Date

Revision

SAAMI 2015 spec vrfd 10/18/22rg

Headspace Gage:	
30 Carbine	
MIN Headspace L3	1.290
Gage Rim Dia R1	.360
Rim Thickness R	.050
Dia Tolerance	+.001/-.000
Length Tolerance	+.005/-.000
Angle Tolerance	+/- 15'
Body TPI	.0174312
L1	
L3	1.290
Drawn:	R Gross
Template	DD M SWTT v1.2

30 Carbine SAAMI