



Standard Inventory Item  
**28 Nosler**

D3D8E9

1/18/2015

5/05/2022

Revision

**Manson Reamers**

Contact us at:  
support@mansonreamers.com  
(810) 953-0732

8200 Embury Rd  
Suite 1  
Grand Blanc, MI 48439

**28 Nosler**

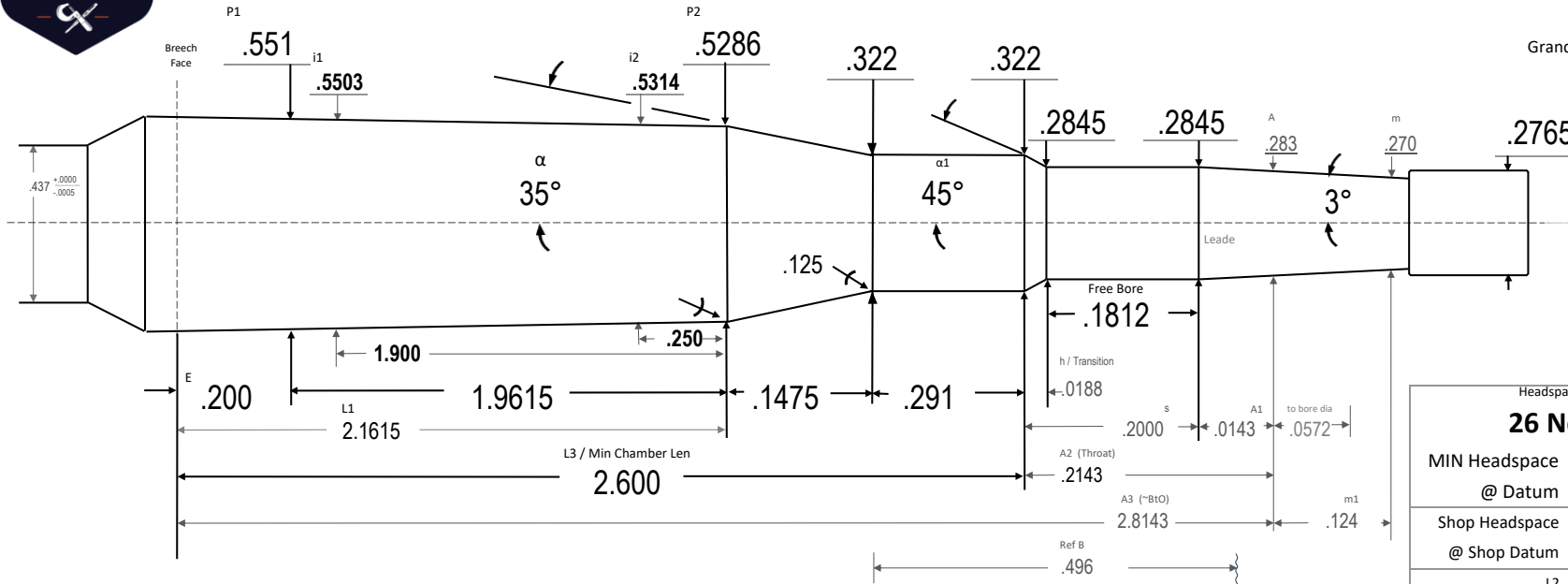

Uses 26 Nosler headspace gages.

Verified SAAMI 2024 24.04.21rg (SAAMI lists groove dia as .2837)

Headspace Gage:	
<b>26 Nosler</b>	
MIN Headspace	2.2390
@ Datum	.4200
Shop Headspace	2.2265
@ Shop Datum	.4375
L2	2.3089 79
Len- Breech to Bore dia	2.8715 54
Body TPI	.0114 29
Breech Face Dia	.5532 86
~Chamber Vol in <sup>3</sup>	.5181 89
Drawn:	Ray Gross
SD	2024.08.06
Template PTL	V10.6 24.08.01
Dia Tolerance	+ .001/- .000
Length Tolerance	+ .005/- .000
Angle Tolerance	+/- 15'
Use Reamer Blank	28 Nos
Print is not to scale	



**28 Nosler**

**28 Nosler**