



Standard Inventory Item  
**250 Savage**

8BD0BB

5/29/1979

5/02/2022

Revision

Manson Reamers

Contact us at:  
 support@mansonreamers.com  
 (810) 953-0732

8200 Embury Rd  
 Suite 1  
 Grand Blanc, MI 48439

250 Savage

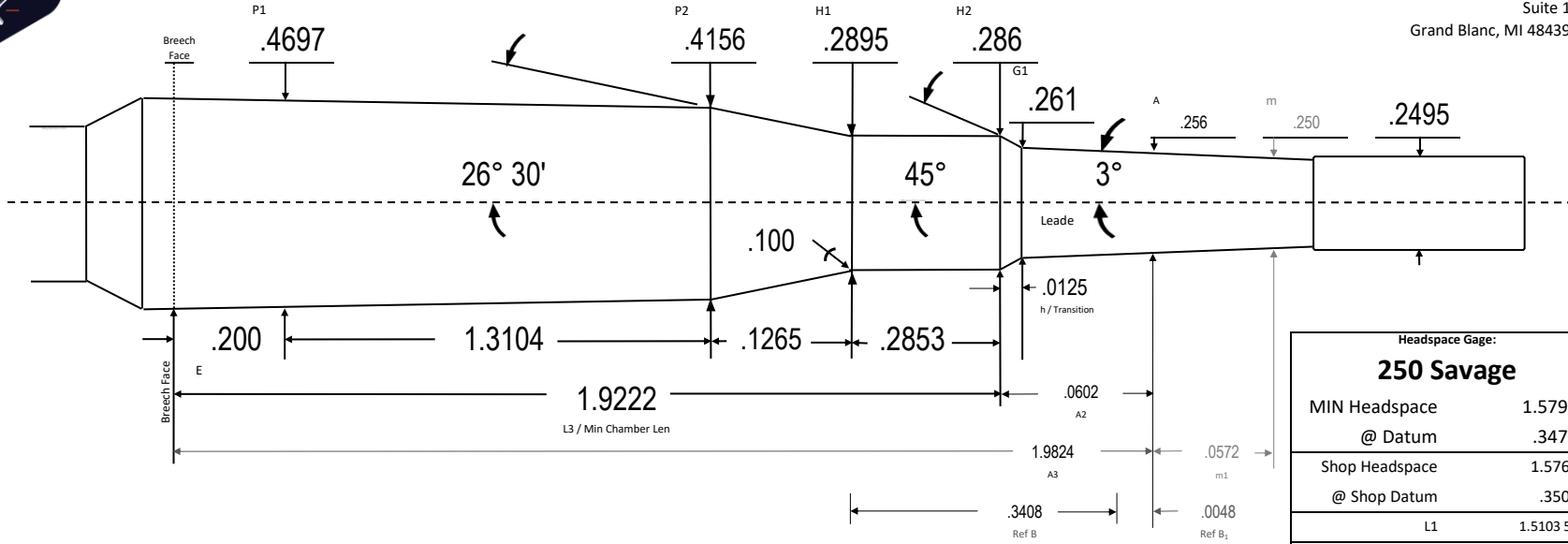

Verified SAAMI 2024 24.04.18rg

reamers dated prior to 06/23 had a tighter body, .468 @ .200 line, neck and throat unchanged

Headspace Gage:	
250 Savage	
MIN Headspace	1.5792
@ Datum	.3470
Shop Headspace	1.5762
@ Shop Datum	.3500
L1	1.5103 57
L2	1.6368 64
A3+m1	2.0396 00
Body TPI	.0412 50
Breach Face Dia	.4779 50
~Chamber Vol in <sup>3</sup>	.2496 72
Drawn:	Ray Gross
SD	2024.07.11
Template TT	V10.5 24.07.11
Dia Tolerance	+ .001/- .000
Length Tolerance	+ .005/- .000
Angle Tolerance	+/- 15'
Use Reamer Blank	257 Rob
Print is not to scale	



250 Savage

250 Savage