



Standard Inventory Item

243 WSSM

E3DF1E

2/11/2004

4/6/2022

Revision

Manson Reamers

Contact us at:
support@mansonreamers.com
(810) 953-0732

8200 Embury Rd
Suite 1
Grand Blanc, MI 48439

243 WSSM

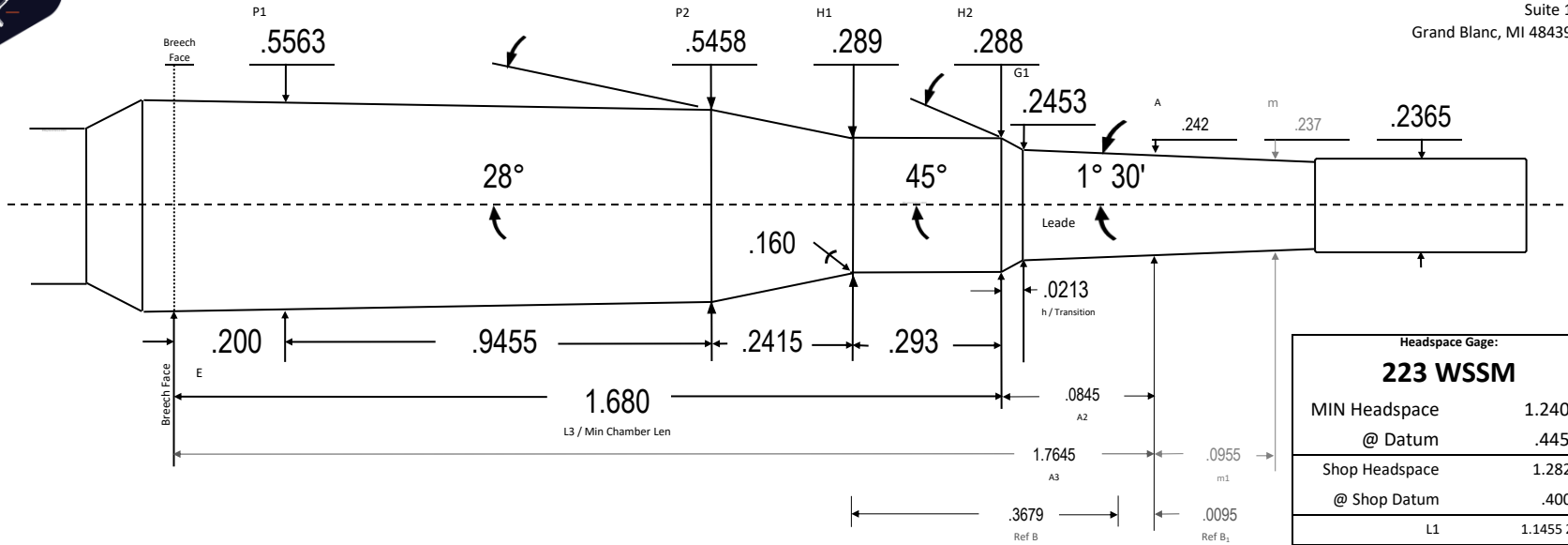

SAAMI 2015 vrfd 06/14/2023, SAAMI 2024 24.04.17rg

Headspace Gage:	
223 WSSM	
MIN Headspace	1.2403
@ Datum	.4450
Shop Headspace	1.2826
@ Shop Datum	.4000
L1	1.1455 29
L2	1.3869 97
A3+m1	1.8600 00
Body TPI	.0111 25
Breach Face Dia	.5585 25
~Chamber Vol in ³	.3083 91
Drawn:	Ray Gross
SD	2024.07.11
Template TT	V10.5 24.07.11
Dia Tolerance	+ .001/- .000
Length Tolerance	+ .005/- .000
Angle Tolerance	+/- 15'
Use Reamer Blank	223 WSSM, 25 WSSM
Print is not to scale	



243 WSSM

243 WSSM