

Manson Precision Reamers

8200 Embury Rd, Grand Blanc, MI 48439

support@mansonreamers.com

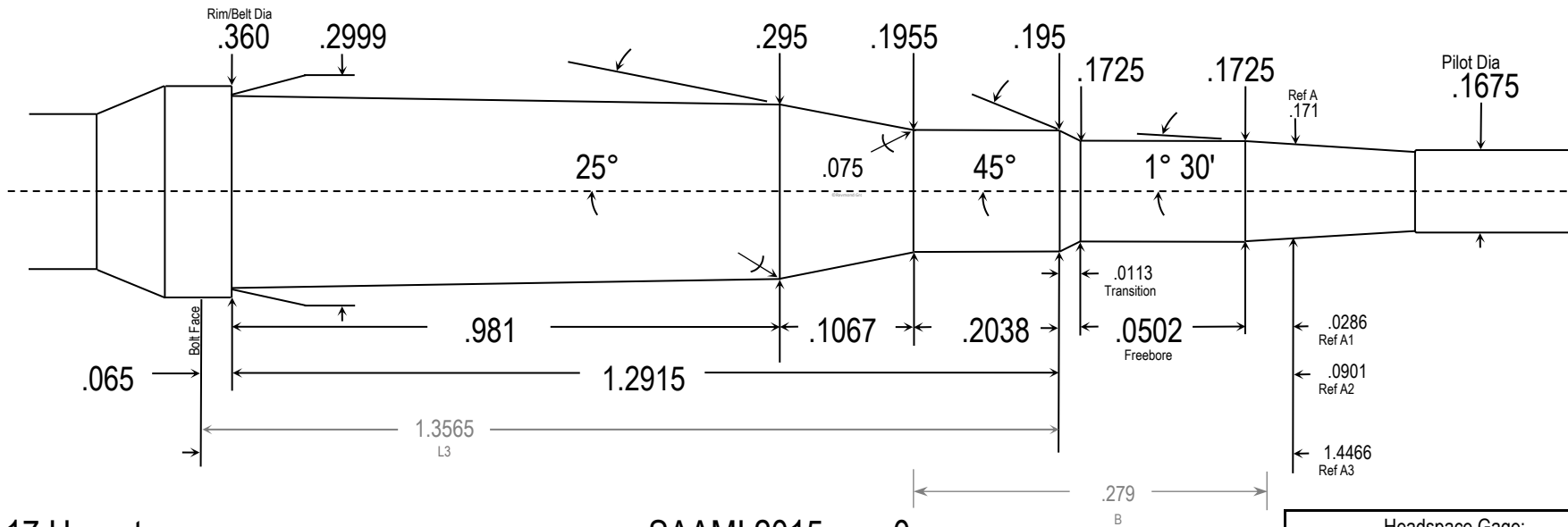

17 Hornet

17 Hornet

SAAMI 2015

0

Design Date

Revision

SAMMI 2015 vrfd 8/21/23

Headspace Gage:	
22 Hornet	
MIN Headspace	.065
Gage Rim/Belt Dia	.350
L1	1.046
L2	1.1527
L3	1.3565
Shoulder Position	1.0589
Shoulder Datum	.283
Body TPI	.00499
Dia Tolerance	+.001/-0.000
Length Tolerance	+.005/-0.000
Angle Tolerance	+/- 10'
Drawn:	R Gross
Template	PT2.1b 12/1/22