



Standard Inventory Item  
**7 Rem Ultra Mag**

C45374

2/1/2002

12/07/2021

Revision

**Manson Reamers**

Contact us at:  
support@mansonreamers.com  
(810) 953-0732

8200 Embury Rd  
Suite 1  
Grand Blanc, MI 48439

**7 Rem Ultra Mag**

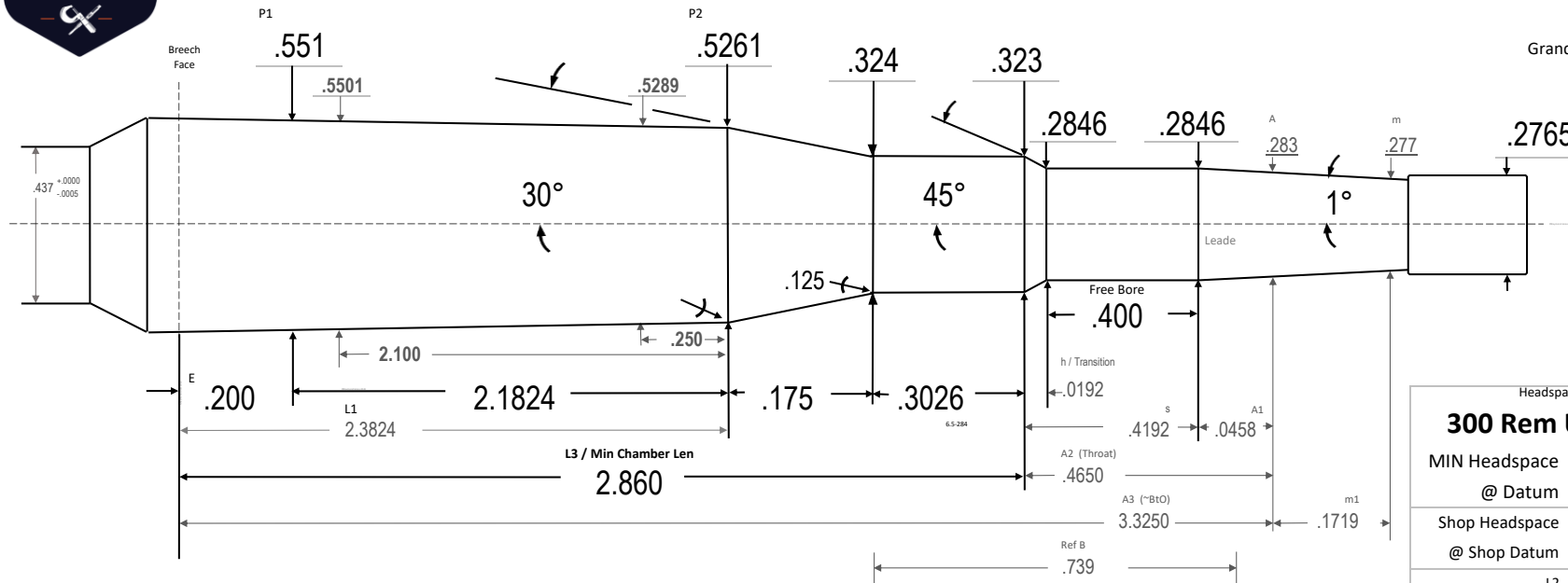

Headspace Gage:	
<b>300 Rem Ultra Mag</b>	
MIN Headspace	2.4742
@ Datum	.4200
Shop Headspace	2.4915
@ Shop Datum	.4000
L2	2.5573 38
A3+m1	3.4968 7
Body TPI	.0114 29
Breech Face Dia	.5532 86
~Chamber Vol in <sup>3</sup>	.5703 61
Drawn:	Ray Gross
SD	2024.06.07
Template PTL	V10.3 24.05.24
Dia Tolerance	+.001/- .000
Length Tolerance	+.005/- .000
Angle Tolerance	+/- 15'
Use Reamer Blank	0
Print is not to scale	

Uses 300 RUM headspace gages. Note that the 7, 300 & 375 use the same headspace gages. The 338 has it's own separate gages/separate hs spec.

Standard updated to 2015 SAAMI spec 11/2021 vrfd SAAMI 2015 24.02.28rg

**7 Rem Ultra Mag**

**7 Rem Ultra Mag**

