



Standard Inventory Item

7-08 Rem SAAMI

A8FF53

4/21/1980

2/18/2022

Revision

Manson Reamers

Contact us at:
support@mansonreamers.com
(810) 953-0732

8200 Embury Rd
Suite 1
Grand Blanc, MI 48439

7-08 Rem SAAMI

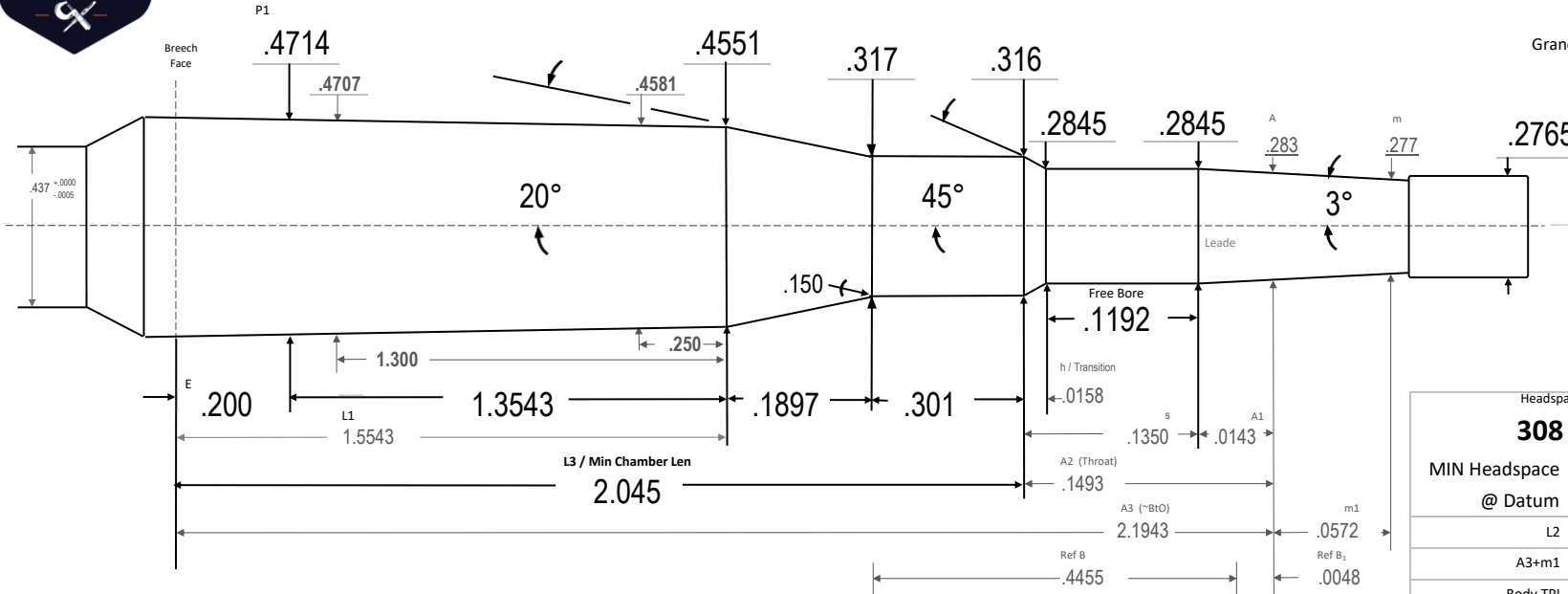

SAAMI 2023 24.02.28 rg

Headspace Gage:	
308 Win	
MIN Headspace	1.6300
@ Datum	.4000
L2	1.7440 2
A3+m1	2.2515 43
Body TPI	.0120 36
Breech Face Dia	.4738 07
~Chamber Vol in ³	.2858 14
Drawn:	Ray Gross
SD	2024.02.28
Template PTL	V10.2 24.01.10
Dia Tolerance	+ .001/- .000
Length Tolerance	+ .005/- .000
Angle Tolerance	+/- 15'
Use Reamer Blank	7mm-08, 308 Win
Print is not to scale	



7-08 Rem SAAMI

7-08 Rem SAAMI