



Standard Inventory Item  
**6.8 Rem SPC II**

9D5ABF

**Manson Reamers**

Contact us at:  
support@mansonreamers.com  
(810) 953-0732

8200 Embury Rd  
Suite 1  
Grand Blanc, MI 48439

**6.8 Rem SPC II**

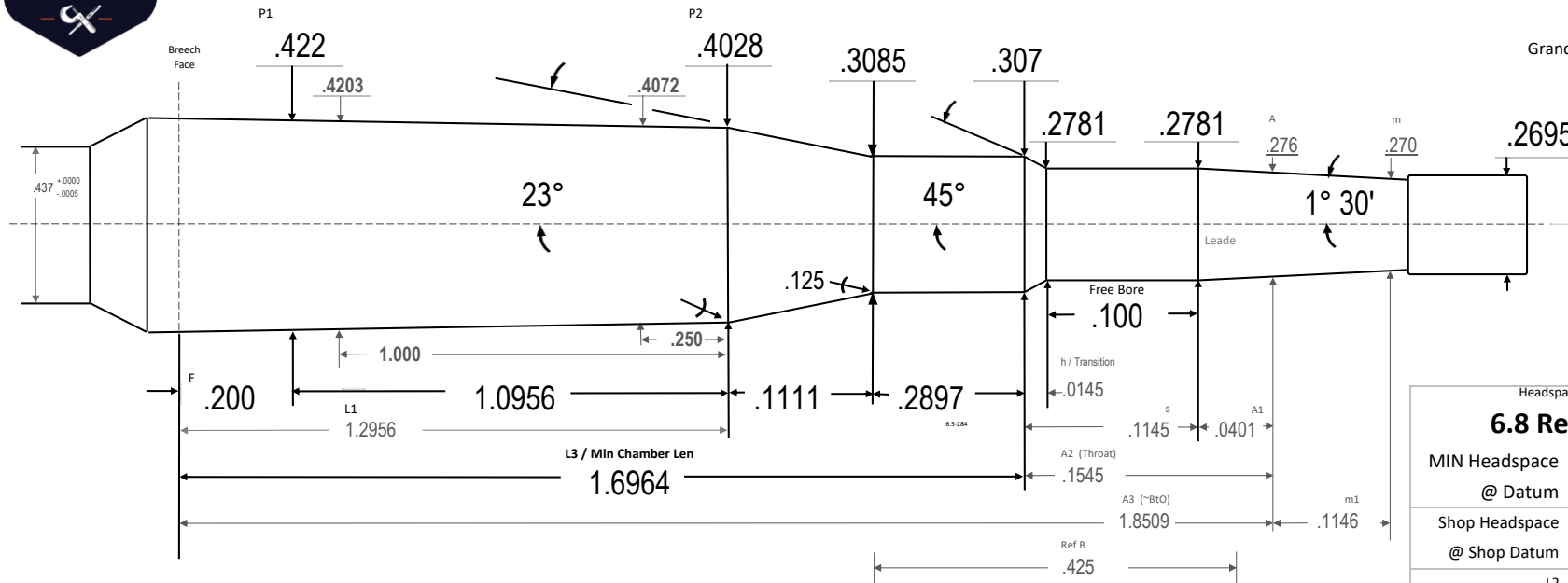

Note: SAAMI 6.8 SPC has a .050 freebore length, the SPC II has a .100 freebore, this is the only difference between the original SPC and the SPC II. SPC II is our Inventory Stock version. The SAAMI reamer can be made to order.

SAAMI 2015 vrfd 24.02.23 ex freebore len

Headspace Gage:	
<b>6.8 Rem SPC</b>	
MIN Headspace	1.3460
@ Datum	.3600
Shop Headspace	1.3578
@ Shop Datum	.3500
L2	1.4066 63
A3+m1	1.9654 65
Body TPI	.0175
Breech Face Dia	.4255
~Chamber Vol in <sup>3</sup>	.1856 84
Drawn:	Ray Gross
SD	2024.06.07
Template PTL	V10.3 24.05.24
Dia Tolerance	+.001/- .000
Length Tolerance	+.005/- .000
Angle Tolerance	+/- 15'
Use Reamer Blank	6.8 SPC
Print is not to scale	



**6.8 Rem SPC II**

**6.8 Rem SPC II**