



Standard Inventory Item  
6.5x55 Swedish SAAMI

6C8873

07/28/1993

12/03/2021

Revision

Manson Reamers

Contact us at:  
support@mansonreamers.com  
(810) 953-0732

8200 Embury Rd  
Suite 1  
Grand Blanc, MI 48439

6.5x55 Swedish SAAMI

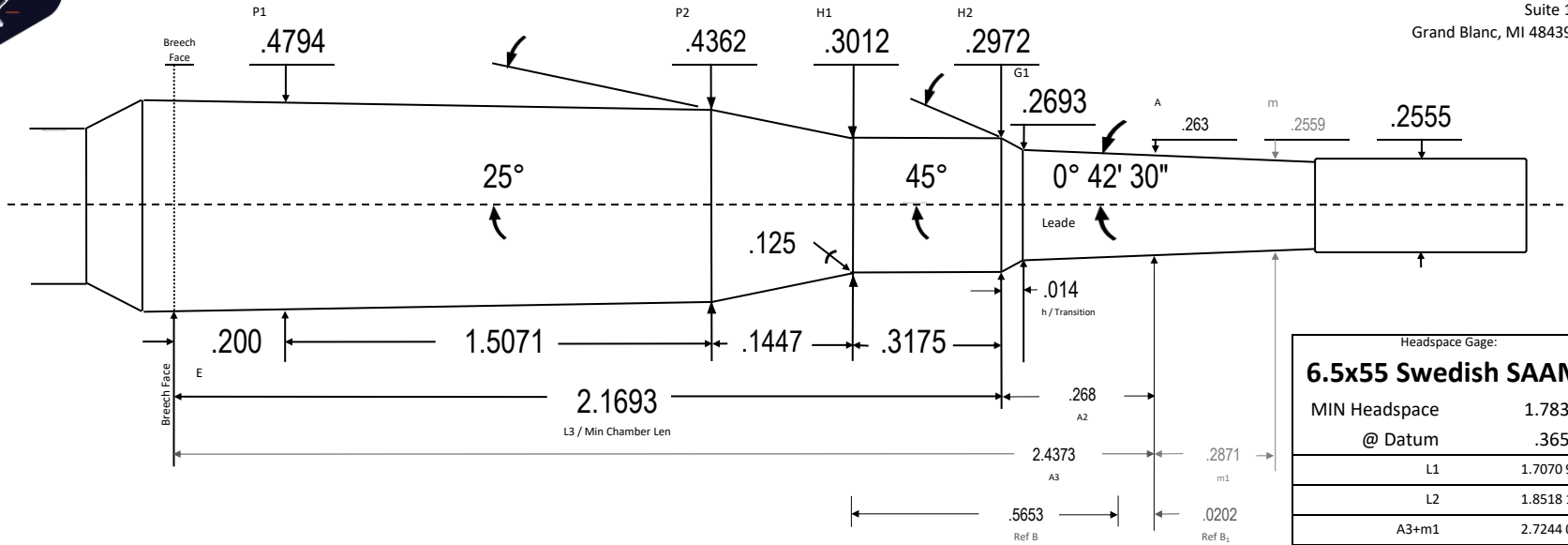

SAAMI 2024 - Translated 2024.06.07

SAAMI shows a cylindrical body section .4815 dia, extending from breech fwd .1268 length. This corresponds with the cartridge extraction groove and falls outside of the barrel

Headspace Gage:	
<b>6.5x55 Swedish SAAMI</b>	
MIN Headspace	1.7834
@ Datum	.3650
L1	1.7070 96
L2	1.8518 10
A3+m1	2.7244 00
Body TPI	.0286 90
Breech Face Dia	.4851 38
~Chamber Vol in <sup>3</sup>	.3003 93
Drawn:	Ray Gross
SD	2024.06.07
Template TT	V10.3 24.05.24
Dia Tolerance	+ .001/- .000
Length Tolerance	+ .005/- .000
Angle Tolerance	+/- 15'
Use Reamer Blank	6.5x55
Print is not to scale	



6.5x55 Swedish SAAMI

6.5x55 Swedish SAAMI