



Standard Inventory Item
6.5x47 Lapua CIP

A1C27D

2006-05-16

2014-05-20

Revision

Manson Reamers

Contact us at:
 support@mansonreamers.com
 (810) 953-0732

8200 Embury Rd
 Suite 1
 Grand Blanc, MI 48439

6.5x47 Lapua CIP

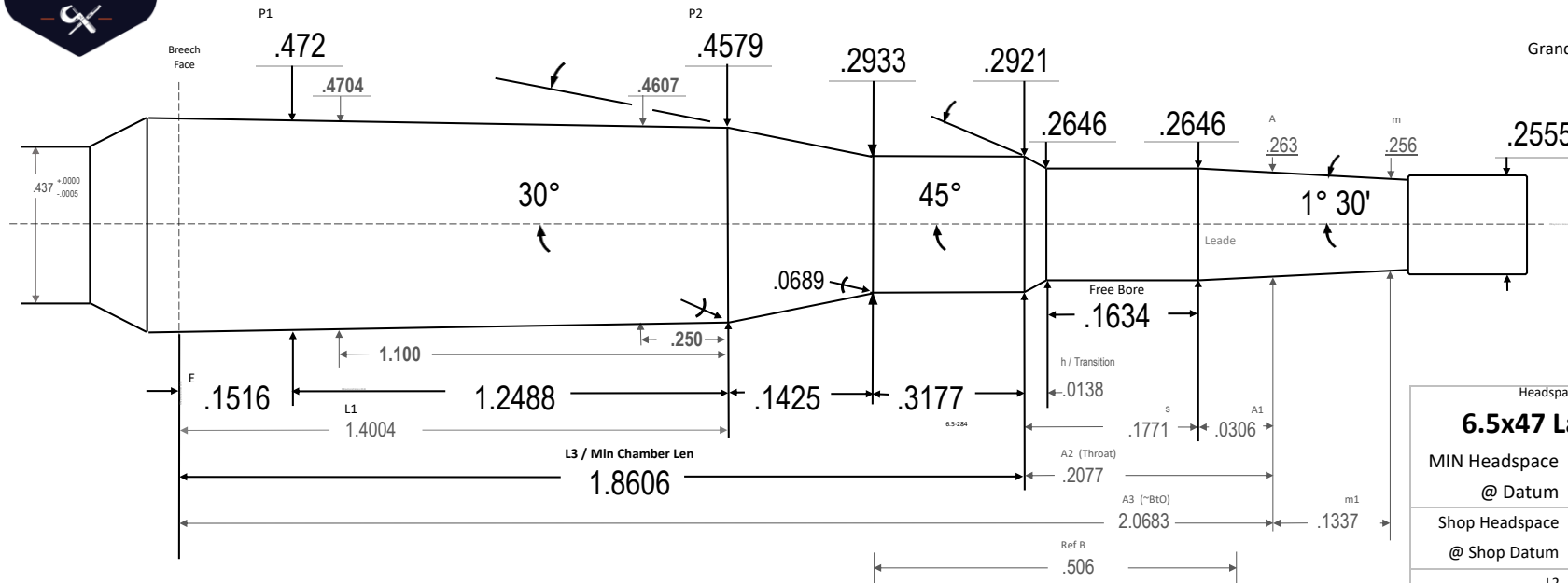

Direct translation of CIP specification 2024/06/04

Headspace Gage:	
6.5x47 Lapua CIP	
MIN Headspace	1.4717
@ Datum	.3756
Shop Headspace	1.4505
@ Shop Datum	.4000
L2	1.5429 13
A3+m1	2.2019 6
Body TPI	.0113 49
.200 line Base Dia	.4714 98
~Chamber Vol in ³	.2547 23
Drawn:	Ray Gross
SD	2024.06.04
Template PTL	V10.3 24.05.24
Dia Tolerance	+.001/- .000
Length Tolerance	+.005/- .000
Angle Tolerance	+/- 15'
Use Reamer Blank	0
Print is not to scale	



6.5x47 Lapua CIP

6.5x47 Lapua CIP