



Standard Inventory Item

6.5 Creedmoor SAAMI

7586BC

06/17/2009

11/16/2021

Revision

Manson Reamers

Contact us at:
support@mansonreamers.com
(810) 953-0732

8200 Embury Rd
Suite 1
Grand Blanc, MI 48439

6.5 Creedmoor SAAMI

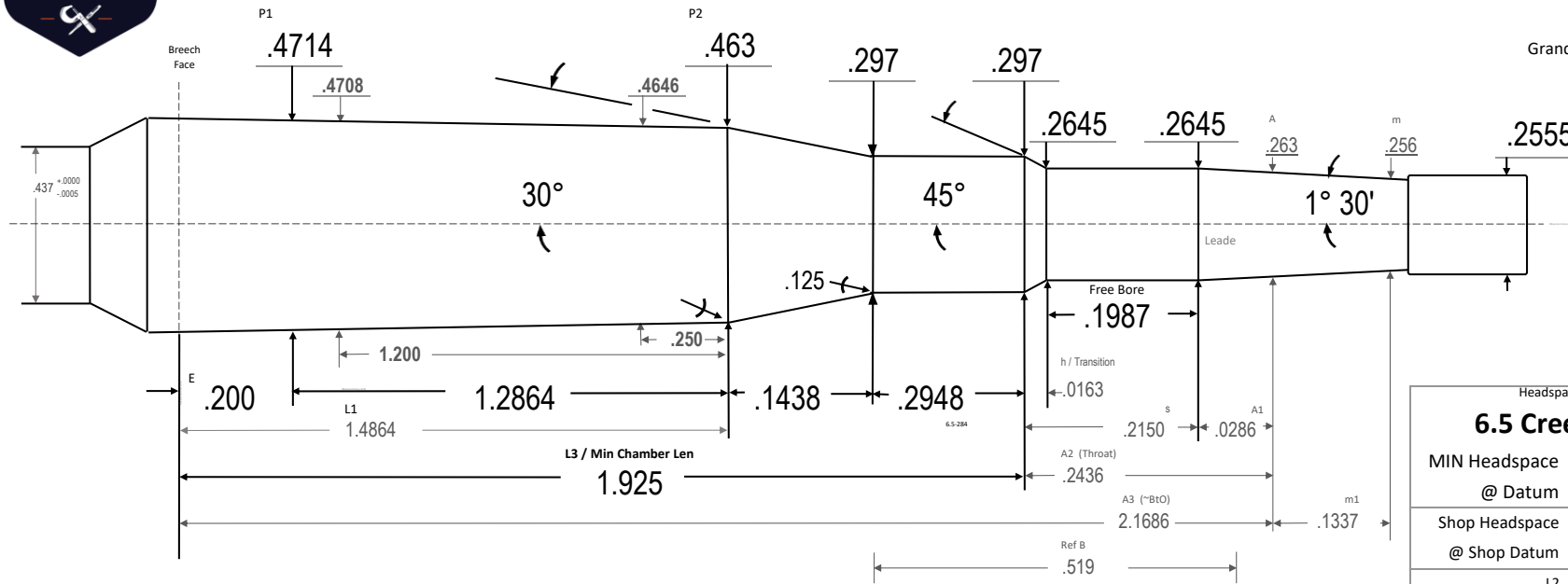

SAAMI 2024 - Translated 2024.06.09 (note the neck mouth dia change from SAAMI 2015, formerly .296)

| Headspace Gage: | |
|------------------------------|----------------|
| 6.5 Creedmoor | |
| MIN Headspace | 1.5410 |
| @ Datum | .4000 |
| Shop Headspace | 1.5410 |
| @ Shop Datum | .4000 |
| L2 | 1.6302 01 |
| A3+m1 | 2.3022 6 |
| Body TPI | .0065 22 |
| Breech Face Dia | .4727 04 |
| ~Chamber Vol in ³ | .2721 19 |
| Drawn: | Ray Gross |
| SD | 2024.06.09 |
| Template PTL | V10.4 24.06.08 |
| Dia Tolerance | +.001/- .000 |
| Length Tolerance | +.005/- .000 |
| Angle Tolerance | +/- 15' |
| Use Reamer Blank | 6.5 CM |
| Print is not to scale | |



6.5 Creedmoor SAAMI

6.5 Creedmoor SAAMI