



Standard Inventory Item
6.5-300 RSAUM

OB1611

1/15/2024

Manson Reamers

Contact us at:
support@mansonreamers.com
(810) 953-0732

8200 Embury Rd
Suite 1
Grand Blanc, MI 48439

6.5-300 RSAUM

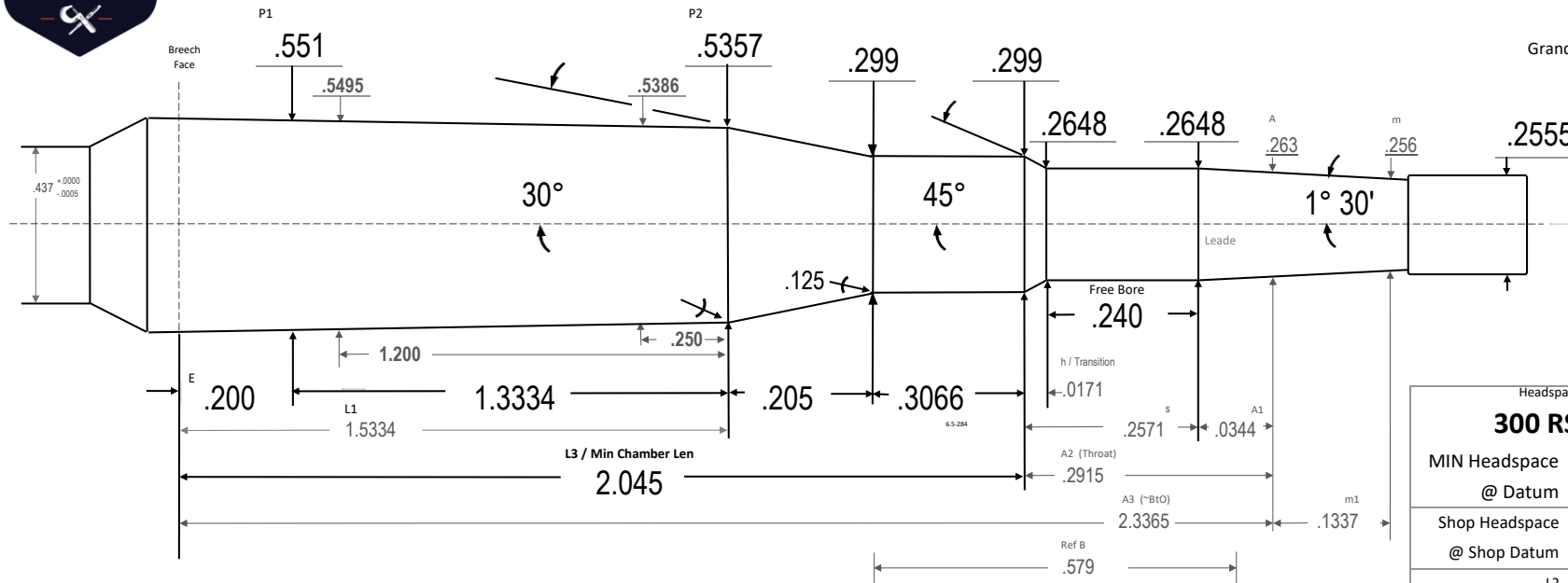

aka 6.5 RSAUM

For use with ADG '6.5 RSAUM' brass or formed from 7 or 300 RSAUM brass

Freebore can be modified to suit customers chosen bullet. Freebore len shown to suit Berger 153.5 LRHybrid & 156 EOL, Hammer 155 Hunter, Hornady 143 ELDX & 147 ELDM (these bullets seated out to the lands will require a medium or long action magazine).

Headspace Gage:	
300 RSAUM	
MIN Headspace	1.5990
@ Datum	.4600
Shop Headspace	1.6185
@ Shop Datum	.4375
L2	1.7384 3
A3+m1	2.4701 6
Body TPI	.0114 74
Breech Face Dia	.5532 95
~Chamber Vol in ³	.3858 93
Drawn:	Ray Gross
SD	2024.06.09
Template PTL	V10.4 24.06.08
Dia Tolerance	+.001/-0.000
Length Tolerance	+.005/-0.000
Angle Tolerance	+/- 15'
Use Reamer Blank	7 WSM
Print is not to scale	



6.5-300 RSAUM

6.5-300 RSAUM