



Standard Inventory Item
6.5-284

8173D5

Manson Reamers

Contact us at:
support@mansonreamers.com
(810) 953-0732

8200 Embury Rd
Suite 1
Grand Blanc, MI 48439

6.5-284

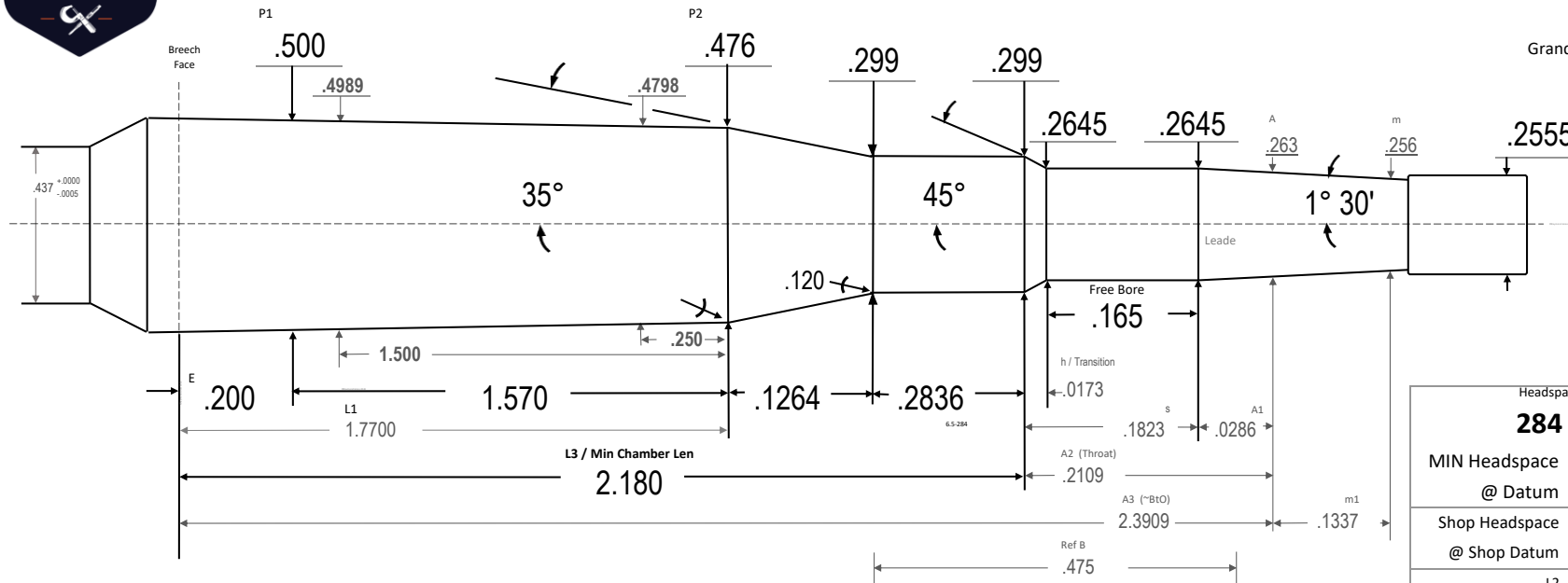

Headspace Gage:	
284 Win	
MIN Headspace	1.8100
@ Datum	.4200
Shop Headspace	1.8243
@ Shop Datum	.4000
L2	1.8964 03
A3+m1	2.5245 6
Body TPI	.0152 87
Breach Face Dia	.5030 57
~Chamber Vol in ³	.3483 87
Drawn:	Ray Gross
SD	2024.06.11
Template PTL	V10.4 24.06.08
Dia Tolerance	+.001/- .000
Length Tolerance	+.005/- .000
Angle Tolerance	+/- 15'
Use Reamer Blank	284 Win
Print is not to scale	

Dave Manson design. Predates the SAAMI adoption. Chamber throat is significantly shorter than the SAAMI or CIP spec. Throat is well suited to Berger 140H, 144LR, Hornady 130 ELDM, Nosler 142 AB, Sierra 142 MK, 120 PH,

Uses standard .284 Win headspace gages. Lapua & Norma

Originally designed for the 142 Sierra, placing it very close to the lands, if seated fully to the neck/shoulder junction. The Berger 140 Hybrid & 140 VLD will be seated .030-.060 forward of the neck/shoulder junction, to be close to the lands.



6.5-284

6.5-284