



Standard Inventory Item  
**6 BRA (BR Ack Imp)**

BFEAB3

**Manson Reamers**

Contact us at:  
support@mansonreamers.com  
(810) 953-0732

8200 Embury Rd  
Suite 1  
Grand Blanc, MI 48439

**6 BRA (BR Ack Imp)**

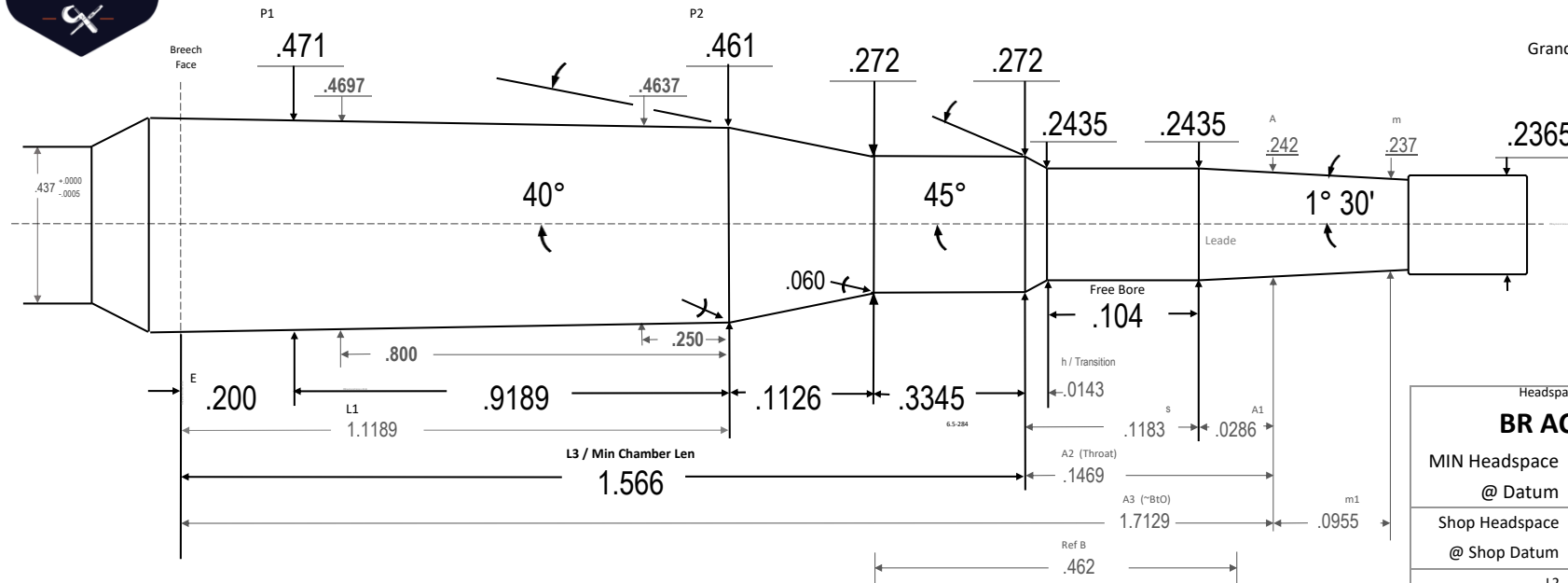

.272 dia is tight, no turn neck, .270 dia requires neck turning with Lapua brass

Standard Ackley conversion method, headspaced by using 6 BR Ackley GO gage. (Ack GO = GO -.004). Will provide crush fit on virgin brass for best fireforming result.

Freebore can be adjusted to suit various bullets. This chamber is well suited to the Berger, Hornady, Nosler and Sierra competition bullets in the 100- 108 gr range and the 115 DTAC. Some hunting bullets may need to be seated below the neck/shoulder junction. Lighter bullets can perform well when seated farther out in th neck.

Headspace Gage:	
<b>BR ACK GO</b>	
MIN Headspace	1.2315
@ Datum	.2720
Shop Headspace	1.1670
@ Shop Datum	.3500
L2	1.2315 5
A3+m1	1.8083 71
Body TPI	.0108 82
Breech Face Dia	.4731 76
~Chamber Vol in <sup>3</sup>	.2038 83
Drawn:	Ray Gross
SD	2024.06.09
Template PTL	V10.4 24.06.08
Dia Tolerance	+.001/- .000
Length Tolerance	+.005/- .000
Angle Tolerance	+/- 15'
Use Reamer Blank	6 BR
Print is not to scale	



**6 BRA (BR Ack Imp)**

**6 BRA (BR Ack Imp)**