



Standard Inventory Item

5.45x39 CIP

712EC2

1992-07-23

2015-05-19

Revision

Manson Reamers

Contact us at:
support@mansonreamers.com
(810) 953-0732

8200 Embury Rd
Suite 1
Grand Blanc, MI 48439

5.45x39 CIP

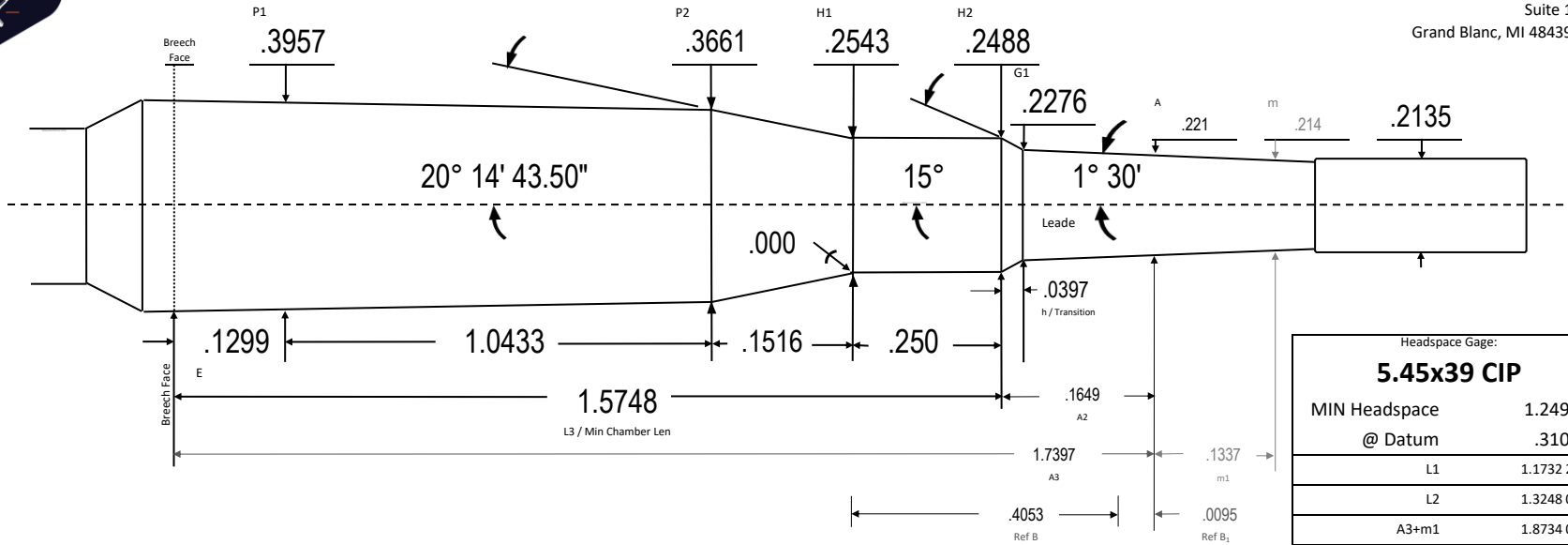

Direct translation of CIP specification 2024/06/09

.214x.222 & .216x.222 are common US barrel Bore & Groove diameters. Customer should specify a pilot diameter .0005 under bore diameter for proper fit.

Headspace Gage:	
5.45x39 CIP	
MIN Headspace	1.2490
@ Datum	.3102
L1	1.1732 28
L2	1.3248 04
A3+m1	1.8734 00
Body TPI	.0283 02
.200 line Base Dia	.3936 86
~Chamber Vol in ³	.1466 55
Drawn:	Ray Gross
SD	2024.06.09
Template TT	V10.4 24.06.08
Dia Tolerance	+ .001/- .000
Length Tolerance	+ .005/- .000
Angle Tolerance	+/- 15'
Use Reamer Blank	5.45x39, 6 CM
Print is not to scale	



5.45x39 CIP

5.45x39 CIP