



Standard Inventory Item
260 Rem Ackley Imp

7E1EBF

Manson Reamers

Contact us at:
 support@mansonreamers.com
 (810) 953-0732

8200 Embury Rd
 Suite 1
 Grand Blanc, MI 48439

260 Rem Ackley Imp

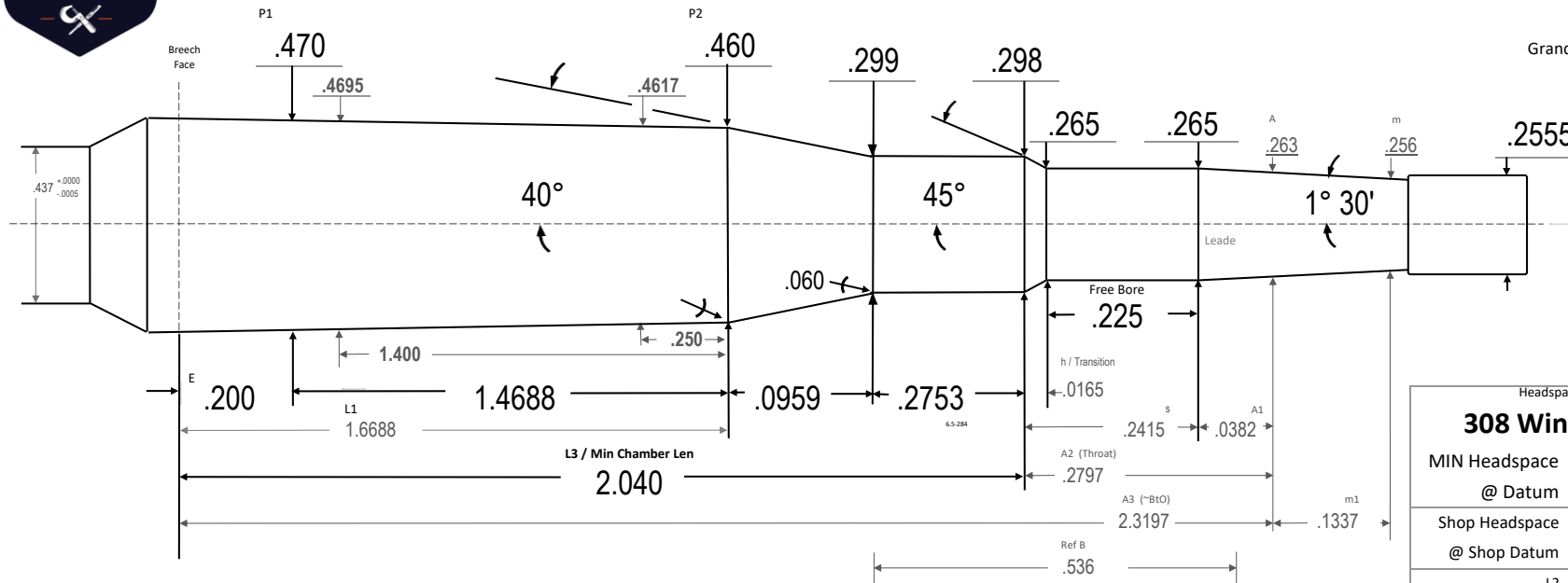

Headspace Gage:	
308 Win ACK GO	
MIN Headspace	1.7647
@ Datum	.2990
Shop Headspace	1.6300
@ Shop Datum	.4000
L2	1.7647 48
A3+m1	2.4533 6
Body TPI	.0068 08
Breech Face Dia	.4713 62
~Chamber Vol in ³	.2952 57
Drawn:	Ray Gross
SD	2024.06.09
Template PTL	V10.4 24.06.08
Dia Tolerance	+.001/- .000
Length Tolerance	+.005/- .000
Angle Tolerance	+/- 15'
Use Reamer Blank	260 Rem, 7mm-08
Print is not to scale	

Uses 308 Ack GO (GO - .004) headspace gages

Throat length can be customized to suit any particular bullet customers may wish to use.

Throat length shown is designed for bullets with longer bearing surface lengths such as the Berger 156 EOL (~COL 3.065), Hornady 147 ELDM (~COL 3.045) or Sierra 140 GameKing (~COL 2.825). If feeding from a standard length (2.825) short action magazine, COL may be too long and bullets will need to be seated deeper and freebore should be shortened accordingly.

Reamers made prior to 07/23 had .100 freebore length

260 Rem Ackley Imp



260 Rem Ackley Imp