



Standard Inventory Item
260 Rem

9AB9AB

1/29/1997

5/03/2022

Revision

Manson Reamers

Contact us at:
support@mansonreamers.com
(810) 953-0732

8200 Embury Rd
Suite 1
Grand Blanc, MI 48439

260 Rem

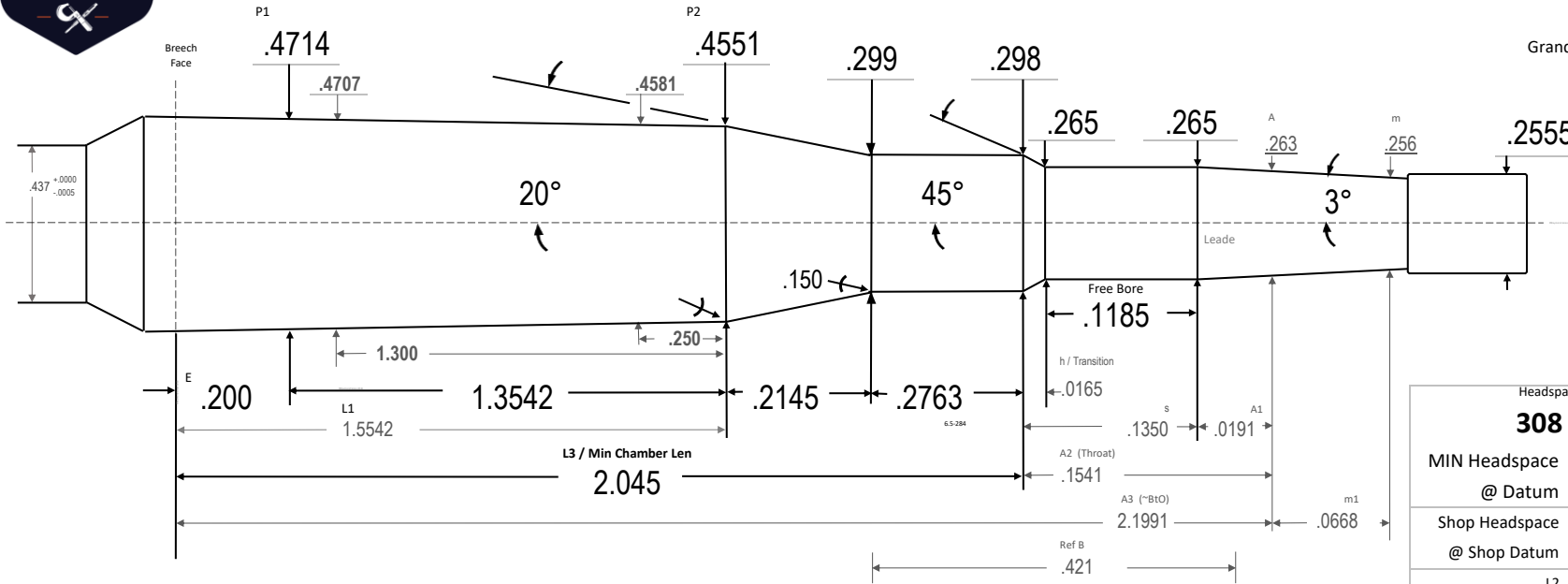

Uses 308 Win headspace gages

SAAMI 2024 Verified 24.04.18rg

Headspace Gage:	
308 Win	
MIN Headspace	1.6300
@ Datum	.4000
Shop Headspace	1.6300
@ Shop Datum	.4000
L2	1.7687 48
A3+m1	2.2658 84
Body TPI	.012
Breech Face Dia	.4738
~Chamber Vol in ³	.2876 8
Drawn:	Ray Gross
SD	2024.06.07
Template PTL	V10.3 24.05.24
Dia Tolerance	+.001/- .000
Length Tolerance	+.005/- .000
Angle Tolerance	+/- 15'
Use Reamer Blank	260 Rem, 7mm-08
Print is not to scale	



260 Rem

260 Rem