



Standard Inventory Item
26 Nosler

6522AD

1/2/2014

05/03/2022

Revision

Manson Reamers

Contact us at:
support@mansonreamers.com
(810) 953-0732

8200 Embury Rd
Suite 1
Grand Blanc, MI 48439

26 Nosler

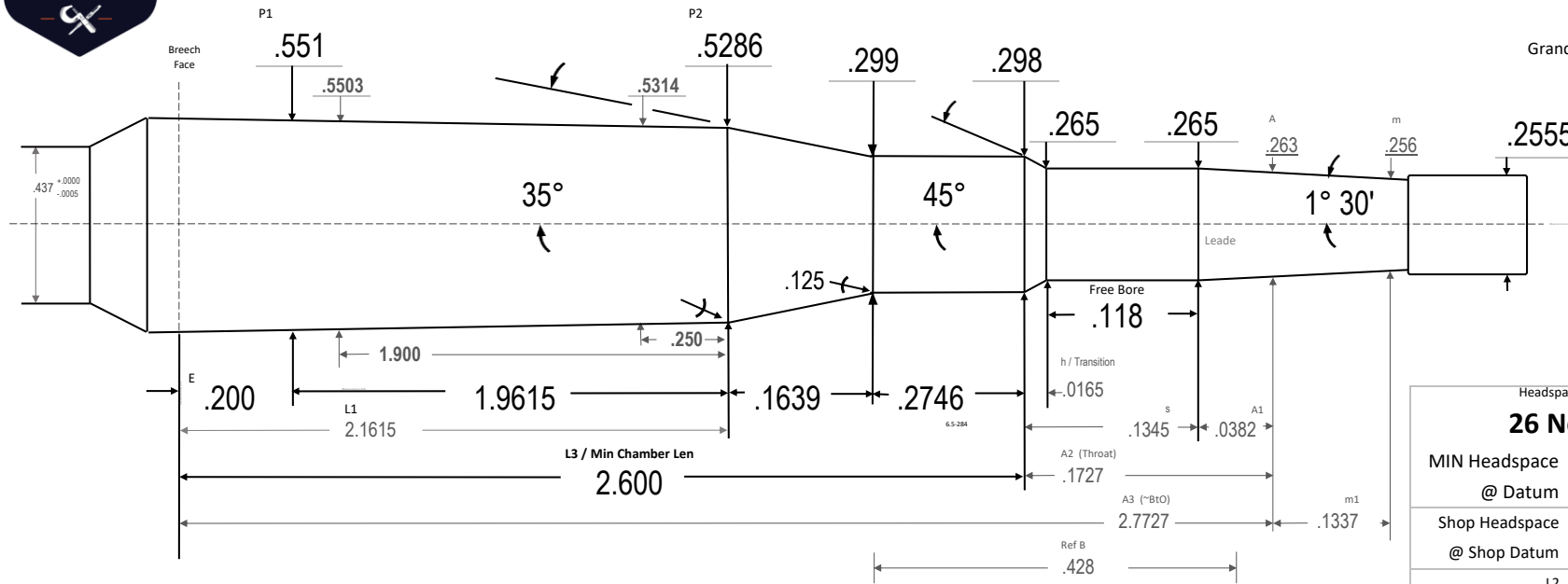

Verified SAAMI 2024 24.04.18rg *note revised lead angle spec of 1° 30'. Previous SAAMI spec (2015) was 3°

Headspace Gage:	
26 Nosler	
MIN Headspace	2.2390
@ Datum	.4200
Shop Headspace	2.2265
@ Shop Datum	.4375
L2	2.3254 03
A3+m1	2.9063 6
Body TPI	.0114 29
Breech Face Dia	.5532 86
~Chamber Vol in ³	.5194 31
Drawn:	Ray Gross
SD	2024.06.07
Template PTL	V10.3 24.05.24
Dia Tolerance	+.001/- .000
Length Tolerance	+.005/- .000
Angle Tolerance	+/- 15'
Use Reamer Blank	26 Nos
Print is not to scale	



26 Nosler

26 Nosler