



Standard Inventory Item

243 Win

0A673F

5/29/1979

4/4/2022

Revision

Manson Reamers

Contact us at:
support@mansonreamers.com
(810) 953-0732

8200 Embury Rd
Suite 1
Grand Blanc, MI 48439

243 Win

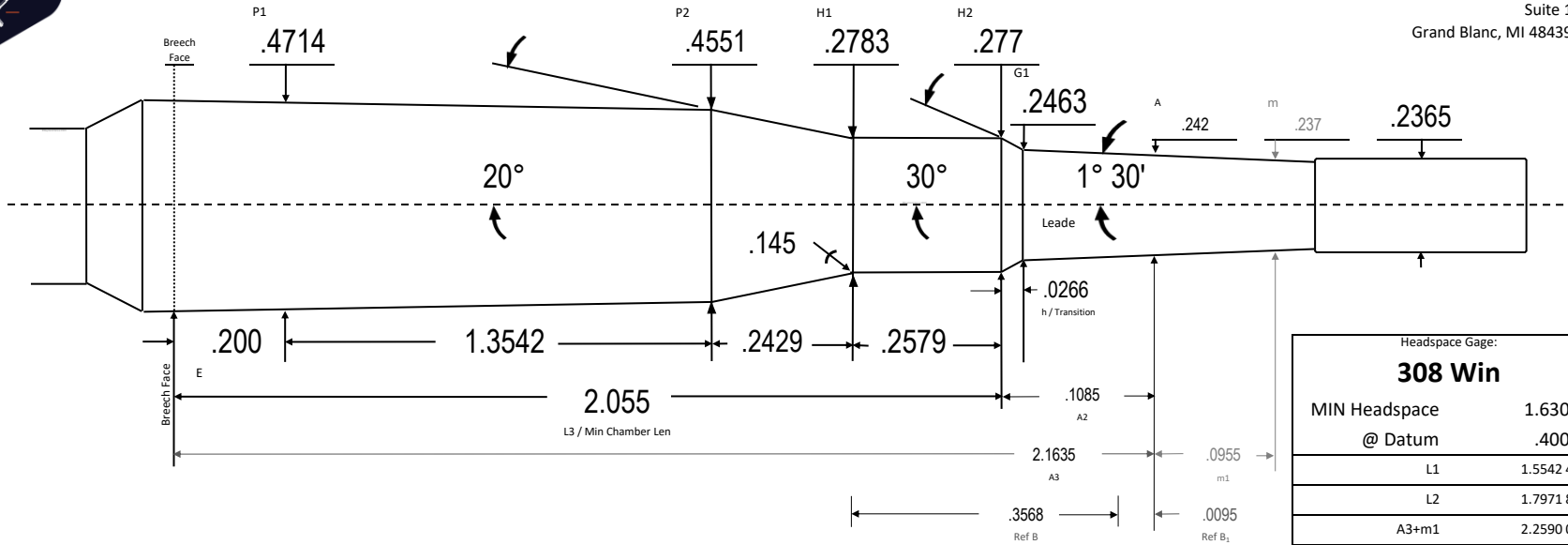

Uses 308 Win headspace gages

SAAMI 2015 vrfd 24.01.13rg, SAAMI 2024 24.04.17rg

Print revised 2023.01.26 to conform with SAAMI 2015 min spec. Reamers made prior had a .470 P1 dia

Headspace Gage:	
308 Win	
MIN Headspace	1.6300
@ Datum	.4000
L1	1.5542 40
L2	1.7971 84
A3+m1	2.2590 00
Body TPI	.0120 00
Breach Face Dia	.4738 00
~Chamber Vol in ³	.2895 38
Drawn:	Ray Gross
SD	2024.05.24
Template TT	V10.3 24.05.24
Dia Tolerance	+ .001/- .000
Length Tolerance	+ .005/- .000
Angle Tolerance	+/- 15'
Use Reamer Blank	243 Win
Print is not to scale	



243 Win

243 Win