



Standard Inventory Item
223 Remington

8AFDDE Manson

Manson Reamers

Contact us at:
 support@mansonreamers.com
 (810) 953-0732

8200 Embury Rd
 Suite 1
 Grand Blanc, MI 48439

223 Remington

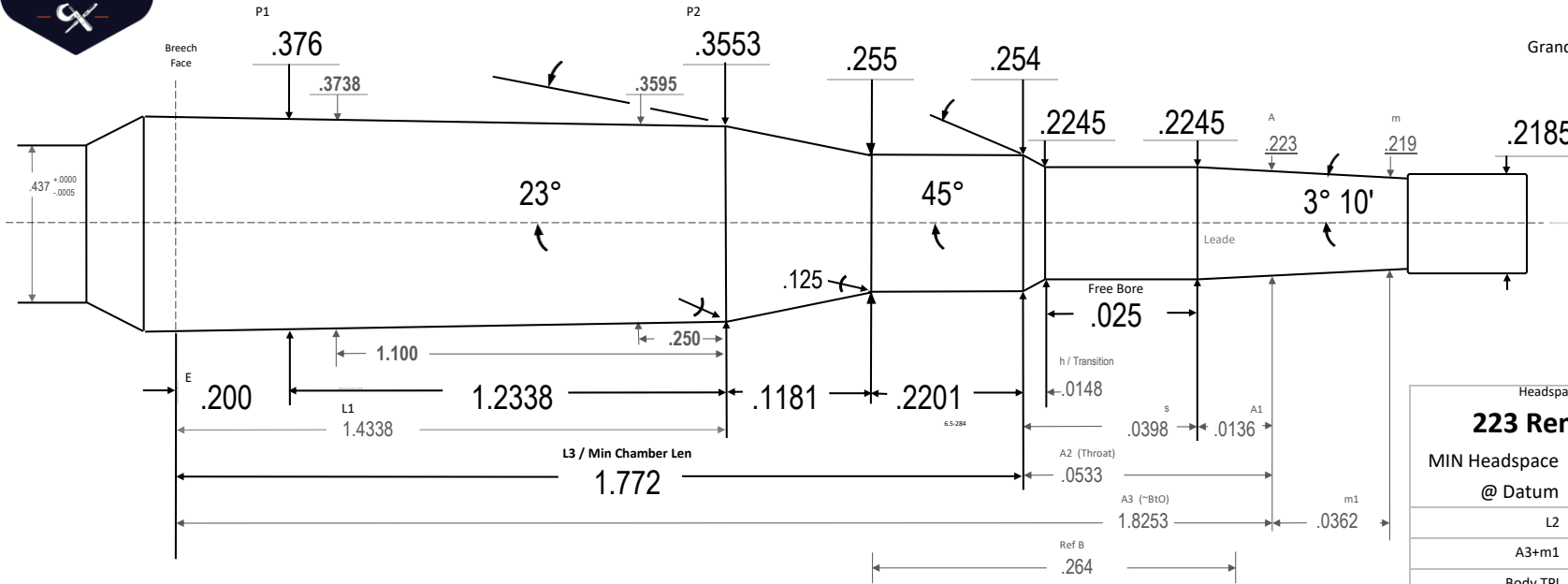

Dave Manson design with base slightly tighter than SAAMI and throat is modified to allow use of a wider range of bullets. (std SAAMI is .3769 @ .200 line, throat is .224x.025fb w/ 3° 10' 36" leade)

Headspace Gage:	
223 Remington	
MIN Headspace	1.4636
@ Datum	.3300
L2	1.5519 44
A3+m1	1.8614 5
Body TPI	.0167 77
Breech Face Dia	.3793 55
~Chamber Vol in ³	.1607 14
Drawn:	Ray Gross
SD	2024.05.24
Template PTL	V10.3 24.05.24
Dia Tolerance	+ .001 / - .000
Length Tolerance	+ .005 / - .000
Angle Tolerance	+ / - 15'
Use Reamer Blank	223 Rem
Print is not to scale	



223 Remington

223 Remington