



Standard Inventory Item
223 Rem Wylde

461C6C

Manson Reamers

Contact us at:
support@mansonreamers.com
(810) 953-0732

8200 Embury Rd
Suite 1
Grand Blanc, MI 48439

223 Rem Wylde

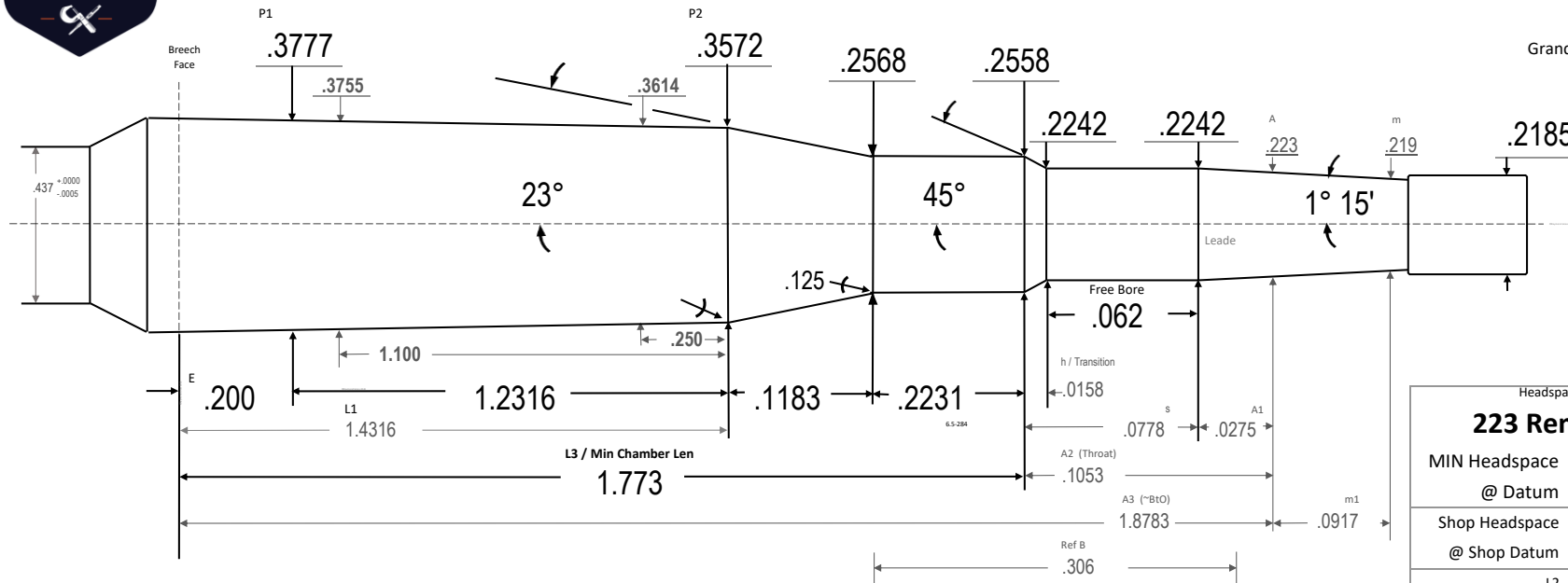

Headspace Gage:	
223 Remington	
MIN Headspace	1.4636
@ Datum	.3300
Shop Headspace	1.4636
@ Shop Datum	.3300
L2	1.5498 24
A3+m1	1.9699 59
Body TPI	.0166 46
Breech Face Dia	.3810 29
~Chamber Vol in ³	.1620 75
Drawn:	Ray Gross
SD	2024.06.08
Template PTL	V10.3 24.05.24
Dia Tolerance	+.001/-0.000
Length Tolerance	+.005/-0.000
Angle Tolerance	+/- 15'
Use Reamer Blank	223 Rem
Print is not to scale	



223 Rem Wylde

223 Rem Wylde