



Standard Inventory Item

222 Rem

B9429B

Manson

Manson Reamers

Contact us at:
support@mansonreamers.com
(810) 953-0732

8200 Embury Rd
Suite 1
Grand Blanc, MI 48439

222 Rem

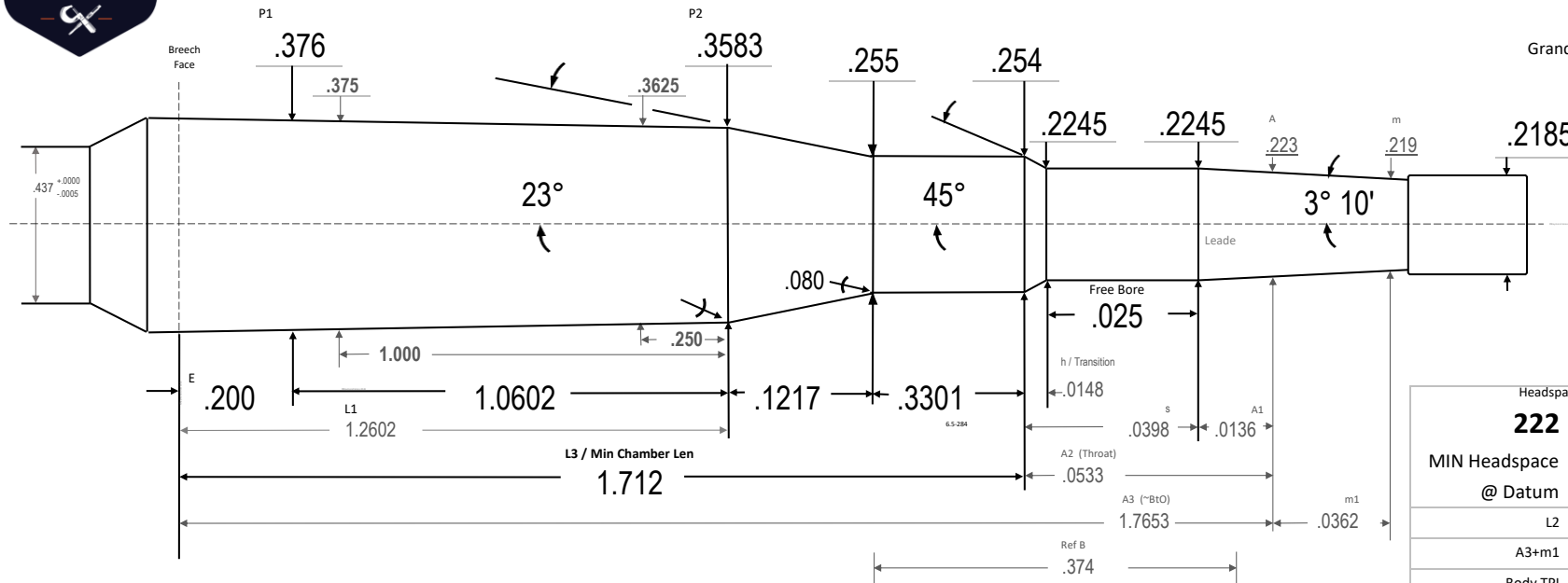

Dave Manson design with base slightly tighter than SAAMI and throat is modified to allow use of a wider range of bullets. (std SAAMI is .3769 @ .200 line, throat is .224x.025fb w/ $3^\circ 10' 36''$ leade)

Headspace Gage: 222 Rem

MIN Headspace @ Datum	1.2936 .3300
L2	1.3819 44
A3+m1	1.8014 5
Body TPI	.0166 51
Breech Face Dia	.3793 3
~Chamber Vol in ³	.1437 6
Drawn:	Ray Gross
SD	2024.05.24
Template PTL	V10.3 24.05.24
Dia Tolerance	+ .001 / - .000
Length Tolerance	+ .005 / - .000
Angle Tolerance	+ / - 15'
Use Reamer Blank	223 Rem
Print is not to scale	



222 Rem

222 Rem