



Standard Inventory Item
220 Swift

307840

8/1/1988

3/30/2022

Revision

Manson Reamers

Contact us at:
support@mansonreamers.com
(810) 953-0732

8200 Embury Rd
Suite 1
Grand Blanc, MI 48439

220 Swift

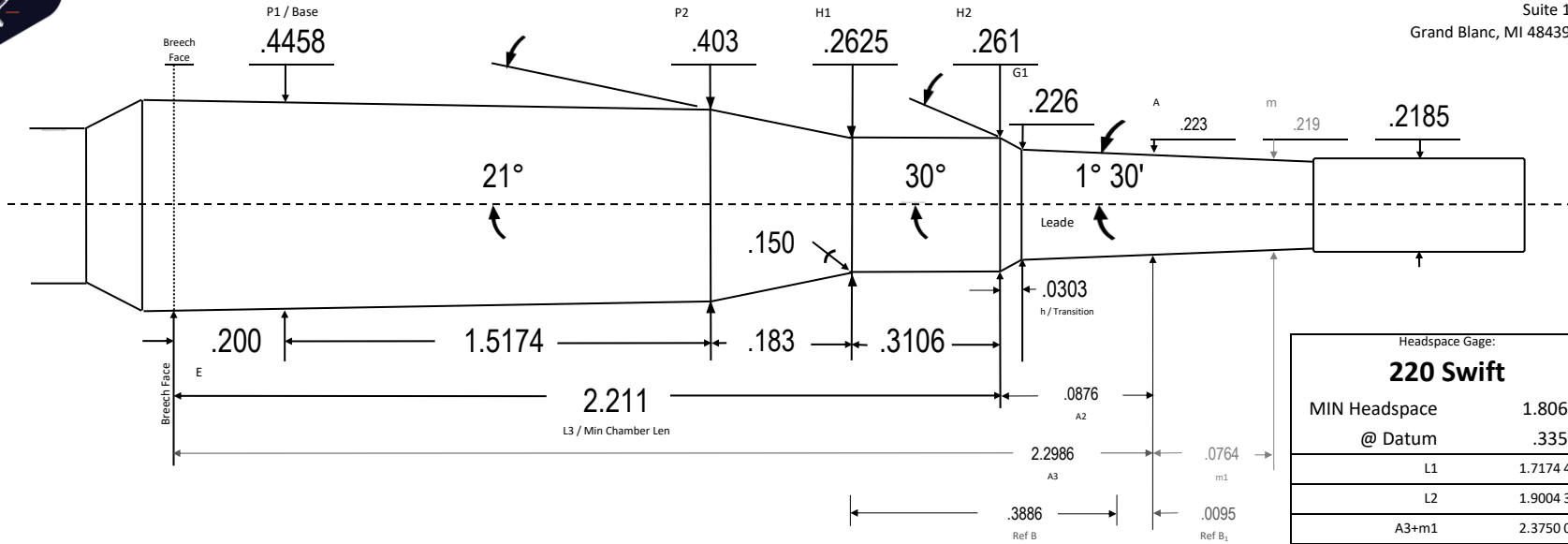

Semi rimmed, headspaces on shoulder

SAAMI 2024 24.04/17rg

| Headspace Gage: | |
|------------------------------|----------------|
| 220 Swift | |
| MIN Headspace | 1.8060 |
| @ Datum | .3350 |
| L1 | 1.7174 45 |
| L2 | 1.9004 34 |
| A3+m1 | 2.3750 00 |
| Body TPI | .0282 14 |
| Breach Face Dia | .4514 43 |
| ~Chamber Vol in ³ | .2626 00 |
| Drawn: | Ray Gross |
| SD | 2024.05.24 |
| Template TT | V10.3 24.05.24 |
| | |
| Dia Tolerance | + .001/- .000 |
| Length Tolerance | + .005/- .000 |
| Angle Tolerance | +/- 15' |
| Use Reamer Blank | 22-250 |
| Print is not to scale | |



220 Swift

220 Swift