



Standard - Made to Order
22-6 GT

1367F1

7/8/2020

Manson Reamers

Contact us at:
 support@mansonreamers.com
 (810) 953-0732

8200 Embury Rd
 Suite 1
 Grand Blanc, MI 48439

22-6 GT

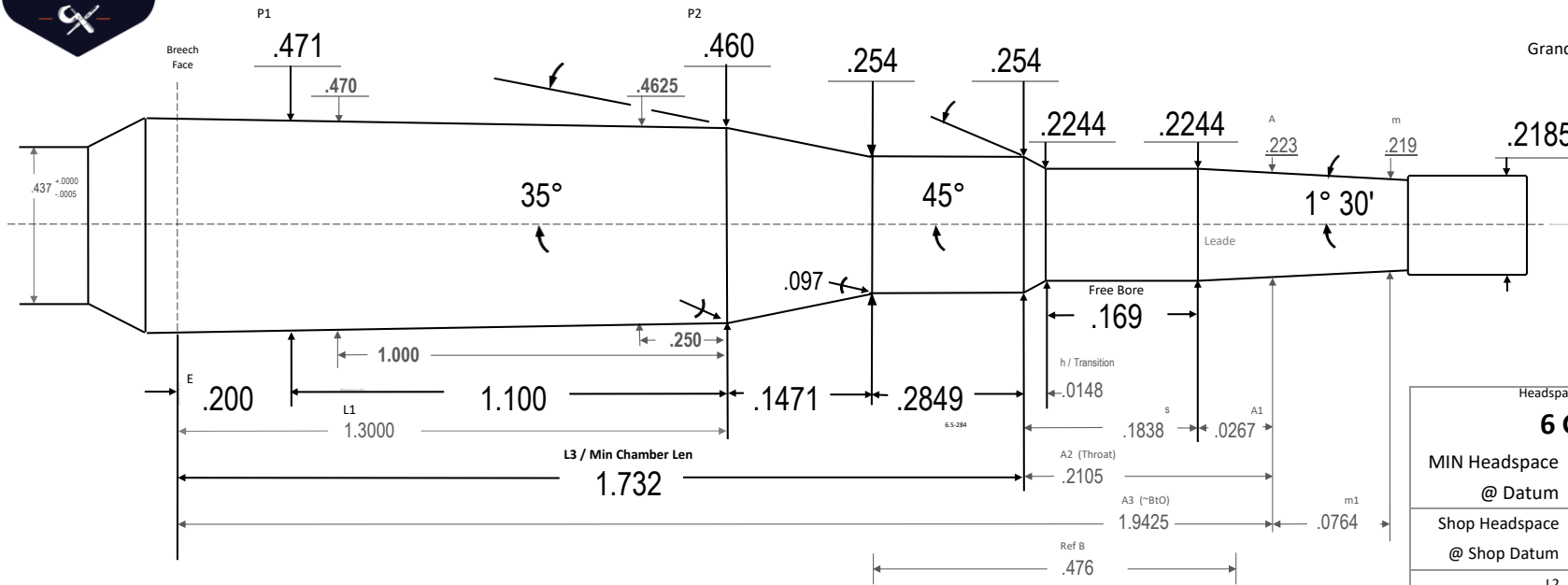

Throated for Hornady 90 gr Atips & 88 ELDM. For Berger 90vld .130 would more suitable. For mid weight bullets .080 freebore would be appropriate- See 22-6 GT Varmint print

Headspace Gage:	
6 GT	
MIN Headspace	1.3607
@ Datum	.3750
Shop Headspace	1.3607
@ Shop Datum	.3750
L2	1.4471 03
A3+m1	2.0188 77
Body TPI	.010
Breech Face Dia	.473
~Chamber Vol in ³	.2373 44
Drawn:	Ray Gross
SD	2024.06.11
Template PTL	V10.4 24.06.08
Dia Tolerance	+.001/- .000
Length Tolerance	+.005/- .000
Angle Tolerance	+/- 15'
Use Reamer Blank	6 BR
Print is not to scale	



22-6 GT

19 9-7Z