



Standard Inventory Item
22-250 Rem

E175F6 Manson

Manson Reamers

Contact us at:
support@mansonreamers.com
(810) 953-0732

8200 Embury Rd
Suite 1
Grand Blanc, MI 48439

22-250 Rem

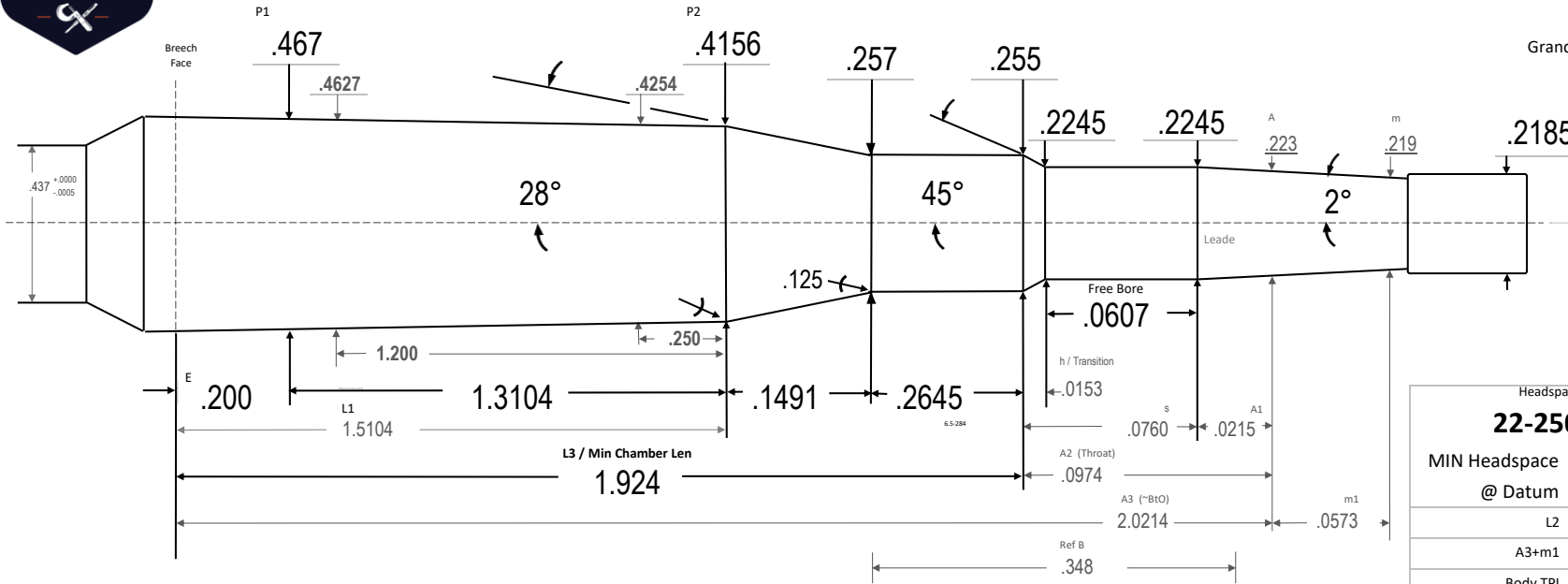

D Manson design. Only P1 dia differs from SAAMI (.4681), all other dimensions SAAMI standard

Headspace Gage:	
22-250 Rem	
MIN Headspace	1.5749
@ Datum	.3470
L2	1.6595 33
A3+m1	2.0786 73
Body TPI	.0392 25
Breech Face Dia	.4748 45
~Chamber Vol in ³	.2489 8
Drawn:	Ray Gross
SD	2024.05.24
Template PTL	V10.3 24.05.24
Dia Tolerance	+ .001 / - .000
Length Tolerance	+ .005 / - .000
Angle Tolerance	+ / - 15'
Use Reamer Blank	22-250, 6 CM
Print is not to scale	



22-250 Rem

22-250 Rem