



Standard - Made to Order

6-6.5 PRC M2

C2BOFE

Manson Reamers

Contact us at:
support@mansonreamers.com
(810) 953-0732

8200 Embury Rd
Suite 1
Grand Blanc, MI 48439

6-6.5 PRC M2

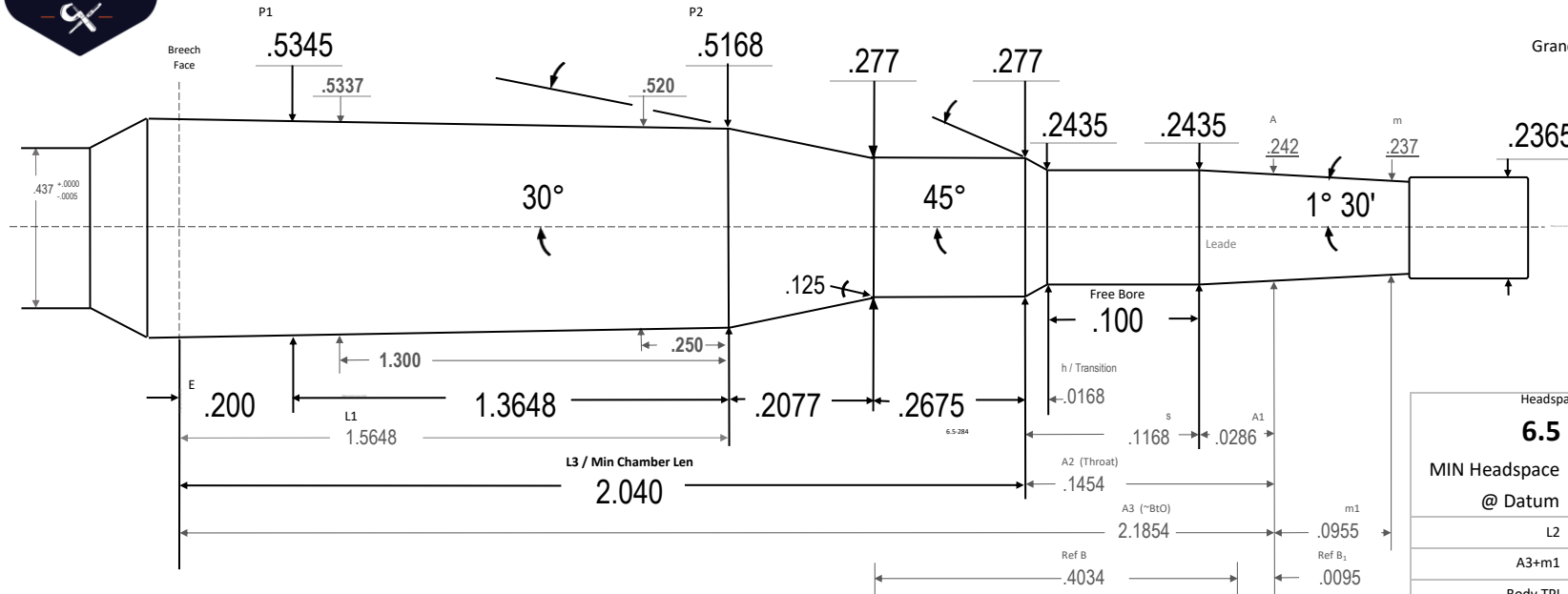

| Headspace Gage: | |
|------------------------------|----------------|
| 6.5 PRC | |
| MIN Headspace | 1.6486 |
| @ Datum | .4200 |
| L2 | 1.7724 42 |
| A3+m1 | 2.2808 71 |
| Body TPI | .0129 69 |
| Breech Face Dia | .5370 94 |
| ~Chamber Vol in ³ | .3677 72 |
| Drawn: | Ray Gross |
| SD | 2024.04.19 |
| Template PTL | V10.2 24.01.10 |
| | |
| Dia Tolerance | +.001/- .000 |
| Length Tolerance | +.005/- .000 |
| Angle Tolerance | +/- 15' |
| Use Reamer Blank | 6.5 PRC |
| Print is not to scale | |

6.5 PRC necked down to 6mm. AKA 6 PRC or 6 SPRC. Uses 6.5 PRC headspace gages

Chamber body is minimum SAAMI spec with the exception of the larger base diameter, to address known extraction issues

Throat is well suited to many (but not all) bullets in the 105-115gr weight range. COL with Berger 105 H seated to the lands will be ~2.900. COL for Hornady 108 ELDM seated to lands will be ~2.880. (COL per published data)

6-6.5 PRC M2

6-6.5 PRC M2

