

7 PRC M1

Standard

Manson Precision Reamers

8200 Embury Rd
Grand Blanc, MI 48439

(810) 953-0732

support@mansonreamers.com

Design Date

Revision

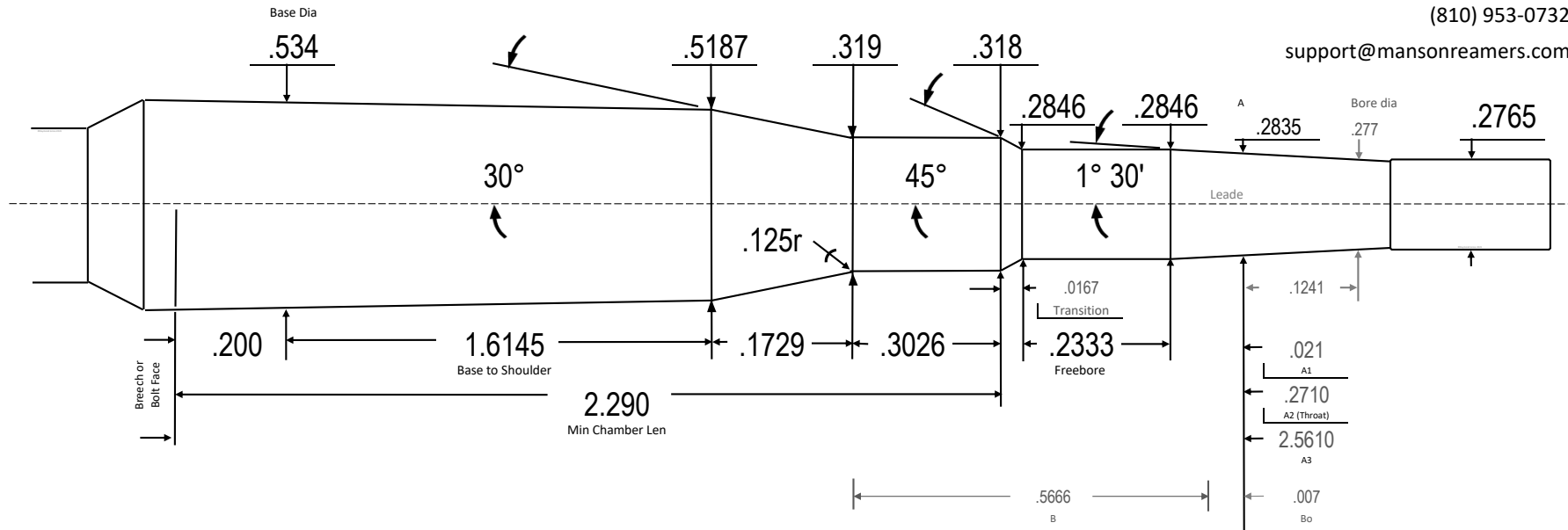

7 PRC M1

7 PRC M1

From Hornady / SAAMI print 1/6/2020

SAAMI headspace of 1.900 to .420 datum converted to 1.9173 to .400 datum

M1 version is SAAMI minimum spec for everything except that the base diameter is .001 larger. (SAAMI is .533). This is to avoid possible sticky extraction that was common with the 6.5 & 300 PRCs. This design remains SAAMI spec, just not 'minimum' spec for the base diameter. The .534 Base diameter is the middle of SAAMI chamber tolerance.

Headspace Gage:	
7 PRC	
MIN Headspace @ Datum	1.9173 .400
L1	1.8145
L2	1.9874
Body TPI	.009476
~Chamber Vol in ³	.4206
Drawn:	R Gross
Print Hash	953687
Template	v8c 22.06.15
Dia Tolerance	+.001/-0.000
Length Tolerance	+.005/-0.000
Angle Tolerance	+/- 10'
Print is not to scale	

7 PRC M1